

**COMPARATIVE METHODS OF  
CONCRETE PORTAL FRAME DESIGN**



Bachelor's thesis

Construction Engineering

Visamäki, spring 2014

Letensang A

Visamäki  
Degree programme in Construction Engineering

---

**Author** Letengsang A **Year** 2014

**Subject of Bachelor's thesis** Comparative methods of concrete portal frame design

---

**ABSTRACT**

The objective of this thesis was to design a concrete portal frame with two column spacings of 12 meters and 6 meters and its structural elements in a building located in Hämeenlinna city, Finland. A comprehension study on the concrete design chapter of Eurocode 2 was done before proceeding on the calculation process, the materials' properties. The corresponding capacity diagrams from concrete product manufacturers in Finland can be assistance tools during the calculation process.

The aim of this thesis was to analyse the differences of the structural elements of the concrete portal frame between two column spacings of 12 and 6 meters. First, the design calculation procedures of the structural elements were studied in accordance with "How to Design Concrete Structure using Eurocode 2", which was published by the Concrete Centre, then the designed results were compared with capacity curves of the selected elements which can be found in the websites of Finnish concrete manufacturers. Finally, conclusions of the comparison were drawn. The results turned out to be as expected. Less reinforcement requirement in the columns, less height and width requirement of the roof elements were expected. A useful derivative study of these elements was expectedly generated.

**Keywords** Column reinforcement, Hollow-core slab, TT-slab, HTT-slab, Concrete sandwich wall panel, HI-beam.

**Pages** 22 p, + 38p, Appendices.

---

CONTENTS

1	INTRODUCTION .....	1
2	BASIC INFORMATION .....	6
3	COLUMN DESIGN.....	10
4	ROOF DESIGN.....	11
4.1	Hollow-core slab.....	12
4.2	TT-slab.....	15
4.3	HI-beam.....	17
4.4	HTT-slab.....	18
5	WALL DESIGN.....	19
5.1	Concrete sandwich wall.....	20
6	CONCLUSION.....	21
	SOURCES .....	22

Appendix 1 Basic design of the concrete portal frame

Appendix 2 Calculation with column spacing of 6 meters (columns design, foundation design, roof design, and HI-beam design)

Appendix 3 Calculation with column spacing of 12 meters (columns design, foundation design, roof design, and HI-beam design)

## 1 INTRODUCTION

The purpose of this thesis was to design the structural elements of a concrete portal frame with different column spacings of 12m and 6m. The structure elements include the roof system, external wall, column, primary beam, and pad foundation. The concrete portal frame has a span of 24 meters transversally and a length of 48 meters longitudinally. The length is separated by columns with intervals, as spacings. The height of the frame is defined as 7.5 meters, and the height of the column is 6 meters. In the studying of the past, concrete portal frame design was taught in the course “Structural Engineering 2”, where students were able to change the frame span and the column height slightly, but the column spacings were not changed. Therefore, a calculation analysis about the difference in two column spacings would be interesting. The results are refreshing; the amount of the reinforcement of the column changes with the shortened column spacing, the column that requires 4 T32 steel bars on one side of the column in the case of 12 meters turns out to only require 4 T25 steel bars on one side of the column in the case of 6 meters. The prerequisite conditions are that they both have the same cross section of 380\*380mm and the same concrete strength of C50/60. Yet, for the roof system, the hollow core slabs are selected with a height of 150mm in the case of 6 meters and a height of 265mm in the case of 12 meters. The selection of the TT-slabs does not make any change because in both cases the snow load stays the same, which also is the unique load acting upon the roof. The selection of the HTT-slabs does not change either because the variation depends on the span of the building and the acting distributive load, which are the same in both cases. However, the original selections of both TT-slab and HTT-slab do not affect the columns, pad foundations and HI-beams design. For the wall structure design, a pre-cast concrete sandwich panel will be introduced which at last holds a thickness of 390mm in total.

## 2 BASIC INFORMATION

The general material for the building is concrete, C50/60, there are reinforcements in the column which are of B500B. The example frame span is 24m, and the store height is 6m. The optional systems are the column prestressed beam frame or the column beam and the ridge TT-slab frame. The roof elements can be hollow core slabs, TT-slabs, or HTT-slabs.

The consequence class of the building is CC2, which is a medium class for the loss of human life, or economic, social or environmental consequences. The soil is mainly coarse grained soil, which gives a 200kN/m<sup>2</sup> capacity. The foundation system is pad foundation and the primary beam is HI-beam.

The frame is stiffened in the transverse direction by cantilever columns and in the longitudinal direction with bracings between primary supports and cantilever columns. End walls are supported by the wind columns. Below are the 3D model (figure 1), section drawing (figure 2), and floor plan (figure 3) of the building.



Figure 1 Figure 1 3D view of a pre-cast concrete portal frame (Harrington precast concrete)

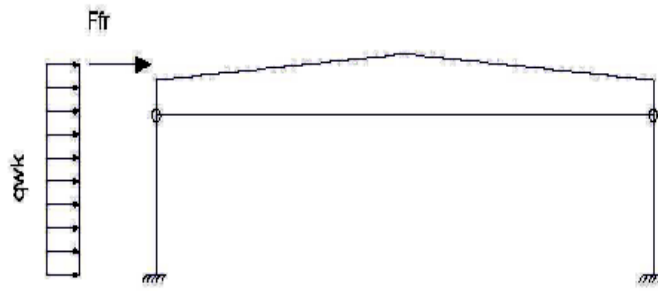

Figure 2 Section plan (<https://moodle.hamk.fi/course/view.php?id=5459>)

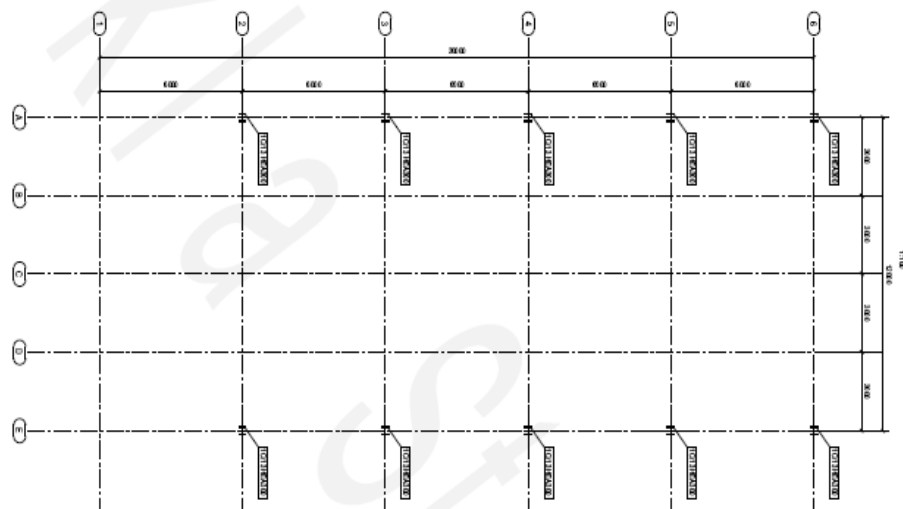

Figure 3 The floor plan (<https://moodle.hamk.fi/course/view.php?id=5459>)

The Loads:

The Vertical Loads:

The vertical loads consist of the dead loads of the roof and the primary beams, the snow load and hanging loads. The building is situated in Hämeenlinna where the snow load on the earth is  $2.5\text{kN/m}^2$ . We determine the characteristic values of the snow loads:

- The snow load on the earth  $S_k=2.5\text{ kN/m}^2$

- The shape coefficient of the pitched roof  $\mu_1=0.8$
- The characteristic value of the snow load on the roof  $q_k=2.0 \text{ kN/m}^2$

The wind load

The wind loads are solved according to the SFS EN 1991-1-x. The resultant of the building's wind force  $F_{,w}$  can be solved with the force coefficient when the plan section is rectangular. In other cases the wind force must be derived as a vector sum of local compression loads. The vector sum of the compression load method can be used to solve the wind loads of a rectangular-formed building. In addition to the wind resultant the friction force  $F_{,fr}$  on the roof level must be observed. The coefficient  $c_{scd}=1.0$  for a one storey building with a height less than 15 m. The frame is designed for the actions of the wind resultant  $F_{,w}$  and the friction force  $F_{,fr}$ .

The load combinations are presented with figure4, 5, 6, 7 and table 1:

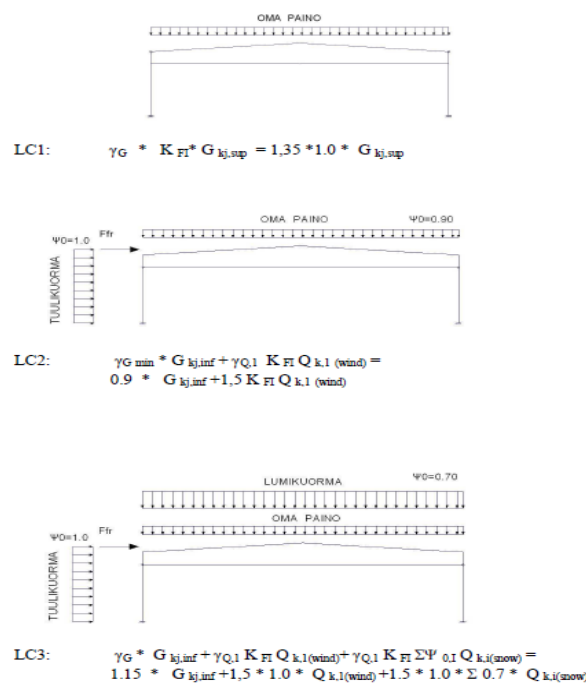

Figure 4 Load combinations sketch(<https://moodle.hamk.fi/course/view.php?id=5459>)

# Comparative method of concrete portal frame design

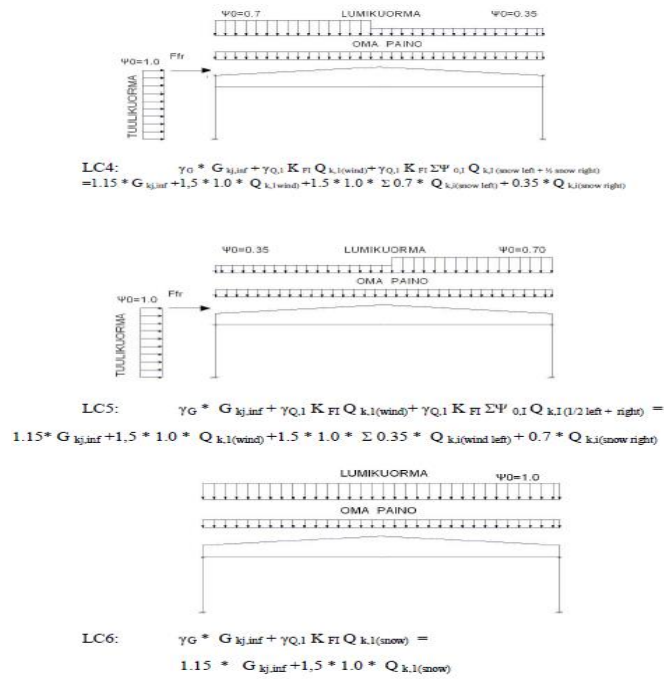

Figure 5 Load combinations sketch(<https://moodle.hamk.fi/course/view.php?id=5459>)

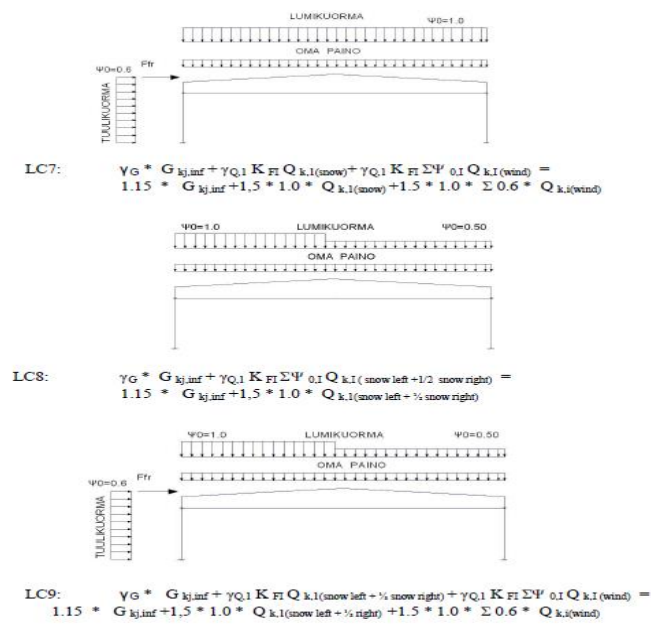

Figure 6 Load combinations sketch(<https://moodle.hamk.fi/course/view.php?id=5459>)



## Comparative method of concrete portal frame design

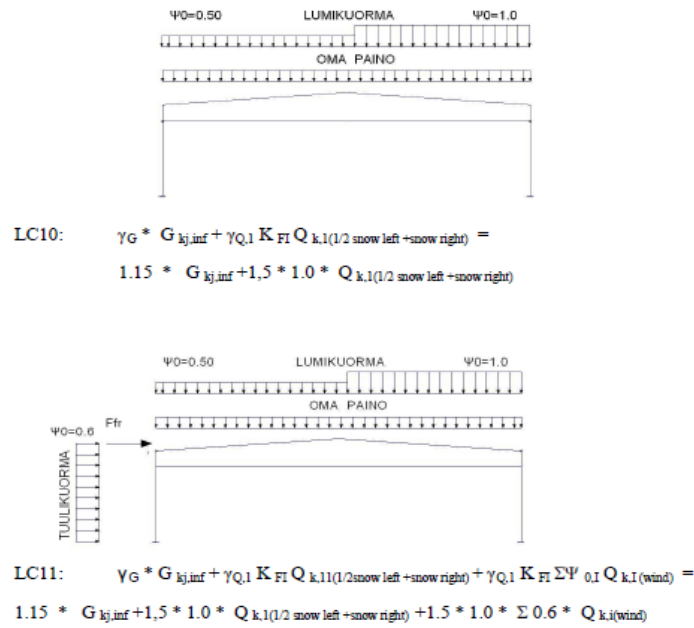

Figure 7 Load combinations sketch(<https://moodle.hamk.fi/course/view.php?id=5459>)

Table 1 Load combination factors (<https://moodle.hamk.fi/course/view.php?id=5459>)

The usual load combinations of a portal frame are presented in the table. The probable determining load combinations are shaded:

		Perm	Wind	Snow		
				l	r	
	LC	ψ0	ψ0	ψ0	ψ0	
G	1	1	0	0	0	
WIND	2	1	1	0	0	
	3	1	1	0.7	0.7	
	4	1	1	0.7	0.35	
	5	1	1	0.35	0.7	
SNOW	6	1	0	1	1	
	7	1	0.6	1	1	
SNOW	L	8	1	0	1	
		9	1	0.6	1	
	R	10	1	0	0.5	1
		11	1	0.6	0.5	1

Partial safety factors

- $\gamma_G = 1.15$  (permanent loads)
- $\gamma_{Gmax} = 1.35$  (permanent loads)
- $\gamma_{Gmin} = 0.90$  (permanent loads)
- $\gamma_Q = 1.50$  (imposed loads)
- $\Psi_0 = 0.70$  (snow)
- $\Psi_0 = 0.60$  (wind)

The load combination 3 is chosen for the design of the frame because it is the most unfavourable ultimate limit state load type.

### 3 COLUMN DESIGN

In the concrete portal frame design, the column always plays a main role. The column not only undertakes the vertical force in terms of dead load and live load (snow load), it also resists the horizontal loads with its end considered fixed by the footings. A column is never exactly centrally load, and there is always some eccentricity, so that there should be always some tolerance in support conditions. The bending moment can be expressed as an apparent eccentricity of the normal force. Column eccentricity is displayed in the figure 8.

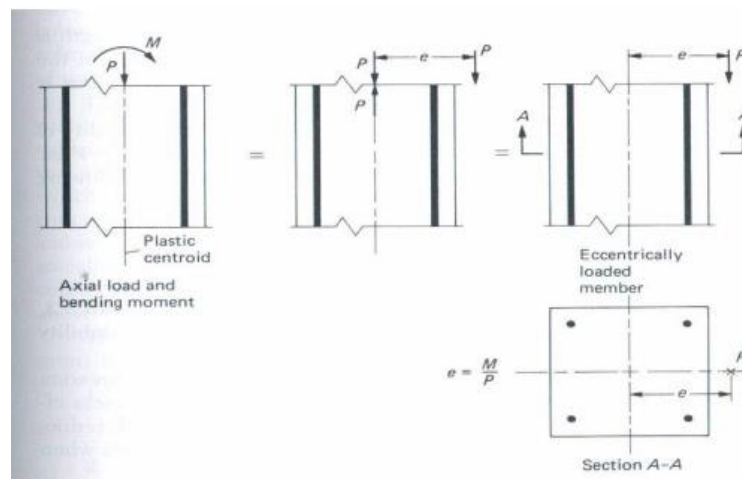

Figure 8 Column eccentricity ( Concise to Eucode2, Concretecentre)

Eccentricity increases as the normal force increases which leads to a higher bending moment (so called second order moment). In this case, the slenderness of the column significantly affects how it behaves, and it is not simply determined by the nominal length of the column. Thus, the effective length is needed which is judged by the end support conditions. The effective length of the column in buckling mode is displayed in the figure 9.

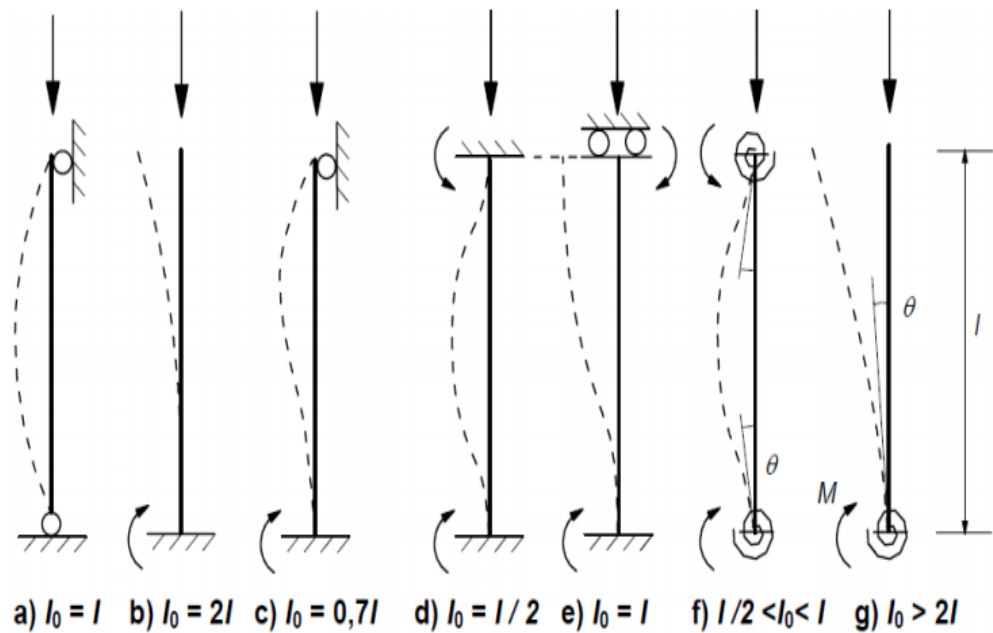

Figure 9 Examples of different buckling modes and corresponding effective lengths for isolated members. (EN1992-1-1, 80P)

The unfavourable effects of possible deviations in the geometry of the structure and the position of loads can increase the bending moment. Deviations in the cross section dimensions are normally taken into account in the material safety factors; these should not be included in structural analysis. Imperfections shall be taken into account in the ultimate limit state in persistent and accidental design situations, and not in serviceability limit states. The effect of imperfections may be applied in two alternative ways: as an eccentricity  $e_i$ , when nominal length equals to effective length or a transverse force  $H_i$ , in the position that gives maximum moment. Isolated members with eccentric axial force or lateral force under braced and unbraced condition is displayed in the figure 10.

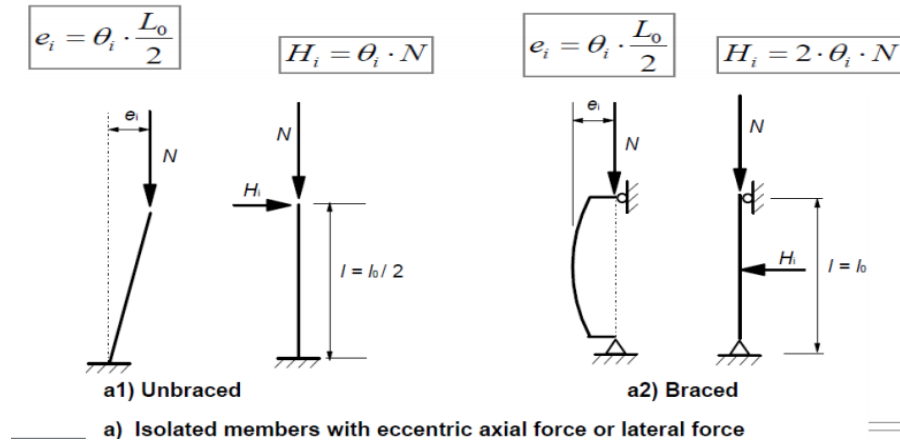

Figure 10 Illustration of isolated members with eccentric axial force under braced and unbraced condition. ( EN 1992-1-1,60P)

If the calculated slenderness of the column is larger than the defined limit slenderness, then the second order effects are taken into account by adding a second order moment which is induced by the additional deflection and the normal force. Therefore, the final design moment is then increased on the basis of the first design moment. After we get the design moment, the next thing is to evaluate the reinforcement in the column. Normally we use column design charts in the design process. In our case, the chart should be illustrated as in the figure 11:

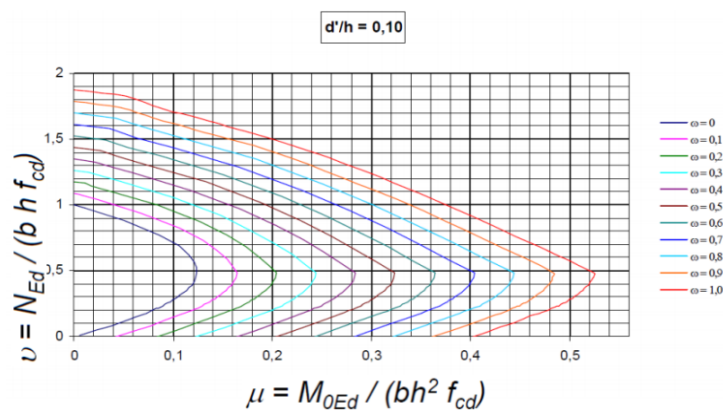

Figure 11 Load bearing capacity curve (Elementisuunnittelu, runkorakenteet)

The concrete of the column is C50/60 and the cross section of the column is 380\*380mm. When calculating out the design moment and the normal force, we then can get the mechanical reinforcement ratio. Because we got the design moment and the normal force of 1100kN, 505kNm for the design with column spacing of 12 meters, and of 620kN, 272kNm (see in the Appendices 2 and 3), for the design with column spacing of 6 meters, and the mechanical reinforcement ratios turned out to be 0.6 in 12 meters case and 0.4 in 6 meters case according to the chart. Thus, logically the final design reinforcement is 4 steel bars with a diameter of 32mm (note as T32), and 4 steel bars with a diameter of 25mm (note as T25) respectively on each side of the column for two cases. (The calculation is in the Appendices 2 and 3).

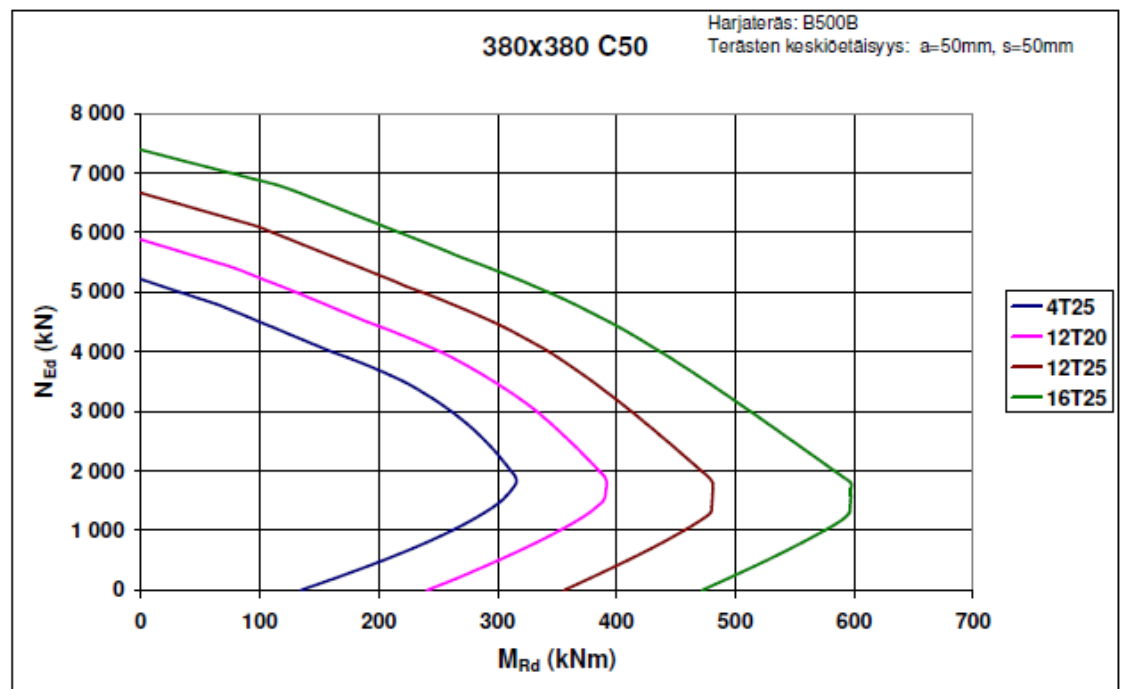

Figure 12 Load bearing capacity of concrete column with reinforcement B500B (Elementtisuunnittelu, runkorakenteet)

In order to verify the result, we need to compare the result with the load bearing capacity curve (See figure 12). First, it is good to calculate out the four definitive reinforcement areas. Through calculations, they are respectively  $1963\text{mm}^2$ ,  $3770\text{mm}^2$ ,  $5890\text{mm}^2$ , and  $7854\text{mm}^2$  for 4T25, 12T20, 12T25, and 16T25. The design reinforcement area in the case of 12 meters is  $6000\text{mm}^2$ , which is quite near, but a little bigger than 12T25's area

However, in the other way 16T25 gives the area which is too large for the design. Ultimately, 4T32 is the most efficient and economical steel bars choice. In this way, 4T25 is the best suitable reinforcement choice in the case of 6 meters.

## 4 ROOF DESIGN

Prefabricated slabs have a number of advantages compared to conventional in-situ roofs. The main advantages are already-made supporting of the low level, speed of construction and working-level achievement at an early stage.

The most common roof elements are hollow-core slabs, TT-slabs, HTT-slabs which are shown in the figure 13.

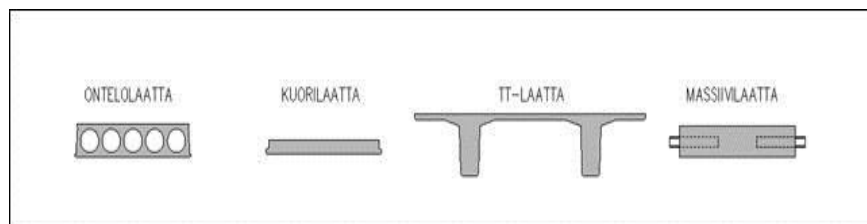
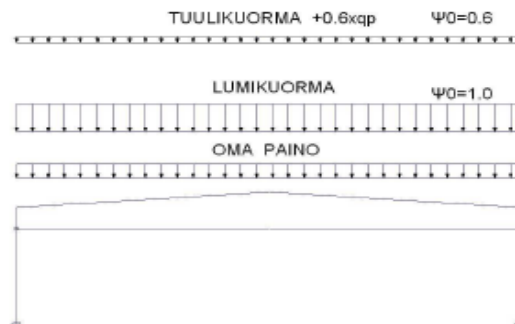

Figure 13 Roof elements (Elementtisuunnittelu, laatat)

Roof choice and type influences the choice of the functional requirements and loads. Functional requirements vary for different building types. The issues of roof type to be observed are:

- A slab span and load capacity
- Architectural requirements, such as the appearance of the underside of a slab
- HVAC installations and other investment structures accession to the roof.
- Sound insulation, especially in residential buildings
- Shape of the building and slabs with openings may influence the election.
- Slabs with your weight can influence the choice of processing elements and other structures bearing capacity.

There are 14 load combinations in our preliminary design of the concrete portal frame, from which we can get the roof design load case, as shown in the figure 14. All roof designs in our case are following this case.



$$LC\ 13: \gamma_G K_{f1} G_{kj} \text{ (dead load)} + \gamma_{Q,1} K_{f1} Q_{kj} \text{ (snow)} + \gamma_{Q,1} K_{f1} \sum \psi_{0j} Q_{ki} \text{ (wind)} = 1.15 * 1 * G_{kj} \text{ (dead load)} + 1.5 * 1 * Q_{kj} \text{ (snow)} + 1.5 * 1 * \sum 0.6 Q_{ki} \text{ (wind)}$$

Figure 14 Load combination to roof design ( Structural engineering notes, EC\_2)

#### 4.1 Hollow-core slab

Hollow-core slab is the most common element in the tile type, which is used in concrete frame buildings. They are used in residential, commercial and industrial sub-, mid-and upper floors.

Hollow core slabs are pre-stressed slab elements, which have been lightened by the slab's longitudinally extending cavities. Hollow-core slabs are made out of concrete C40-C70. Hollow-core slabs are shown in figure 15.

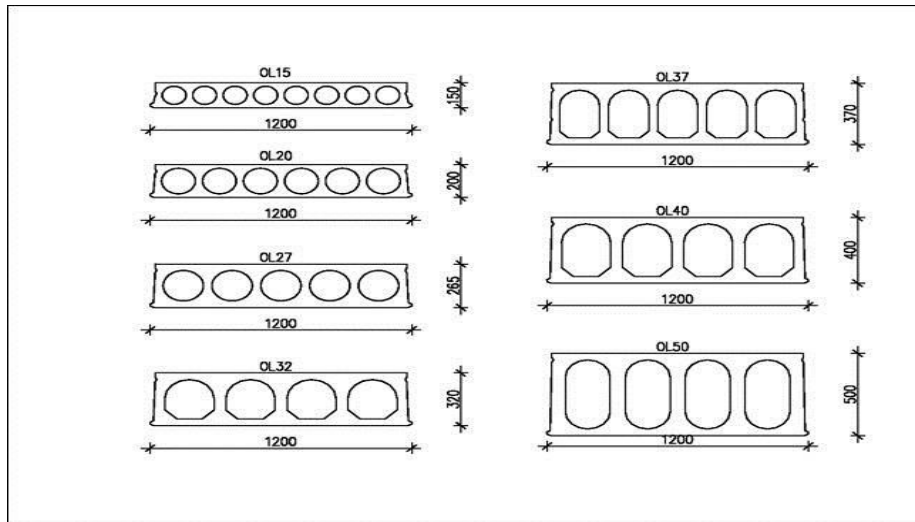

Figure 15 Hollow-core slabs (Elementisuunnittelu, ontelolaatat)

The diameter of the holes, the number and shape of the hollow-core slab vary with altitude. The product-line's heights of hollow-core slab vary with altitude. The product-line's heights of hollow-core slab are 150, 200, 265, 320, 370, 400, and 500 mm. The standard width of the hollow-core slab is 1200mm. The span of hollow-core slab can be possible to reach up to 20 meters. The main hollow-core slabs' properties are shown in the table 2.

Table 2 Hollow-core slabs (Elementisuunnittelu, design manual,7p)

WASHER TYPE	SLAB HEIGHT [mm]	ELEMENT WEIGHT [kg / m <sup>2</sup> ]	Spliced WEIGHT [kg / m <sup>2</sup> ]	VÄHIMMÄISTUKIPINTA [mm]	The maximum span [m]
O15	150	205	215	60	7.0
O20	200	245	260	60	11.0
O27	265	360	380	60	13.5
O32	320	380	400	60	16.0

As shown in the table 2, with a span of 12 meters, the O27 type of hollow core slab could be used. The properties of O27 are shown in the figure 16.



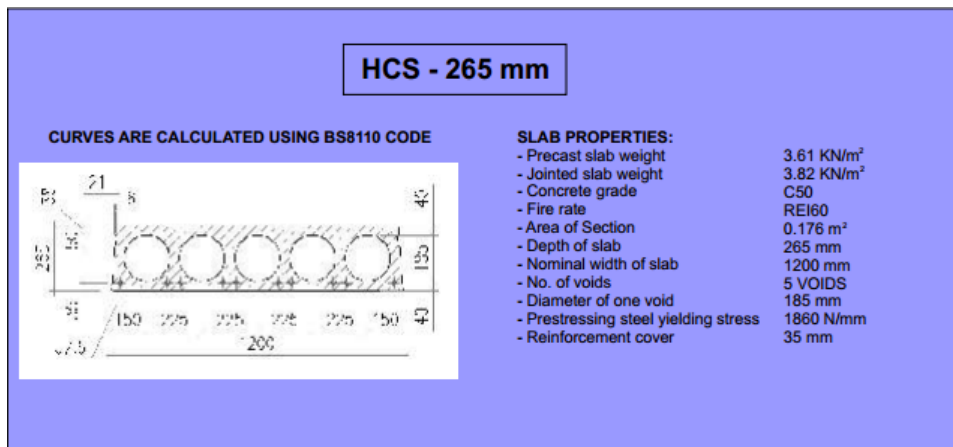

Figure 16 Hollow-core slab property (Elementtisuunnittelu, design manual,8p)

While with a column spacing of 6 meters, the O15 type of hollow core slab could then be used. The properties of O15 are shown in the figure 17.

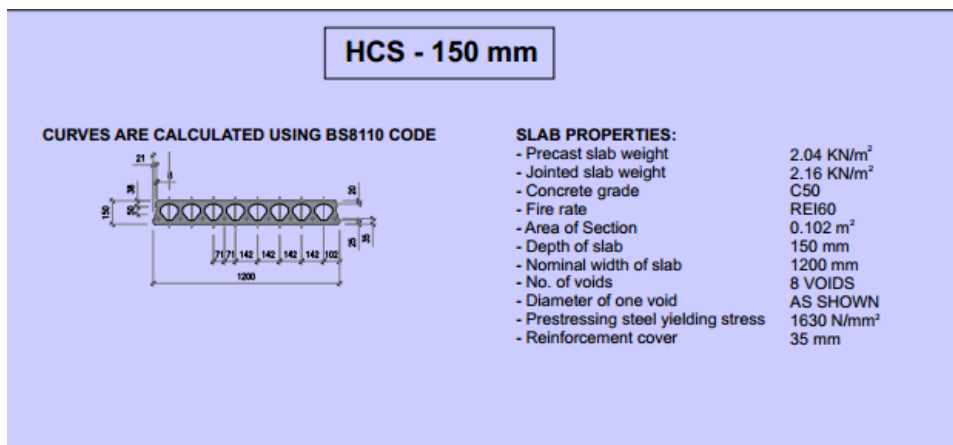

Figure 17 Hollow-core slab property (Elementtisuunnittelu, design manual,9p)

The advantages of the hollow core slab as a roof system are:

- Hollow core slab weighs up to 50 % less than traditional concrete slabs.
- Less construction costs.
- Very mature and efficient production lines provide in-time manufacturing resulting in less congestion on site and cost saving.
- Faster and shorter construction duration.
- It is easy to paint on the smooth bottom of a hollow core slab and it is maintenance free.
- It provides a good load capacity, span range, and deflection control.
- Less sound transmission and vibrations.
- Excellent fire rating.

- The voids in the slab provide good duct for electrical and heating pipes.

#### 4.2 TT-slab

A TT-slab is a pre-stressed reinforced concrete element, which can achieve a long span requirement. Normally the slabs are made of concrete C40. The fire resistance of TT-slab varies from R30-R180. The TT-slabs are produced by using a pre-stressed reinforcement in the tensile zone, and also in the compression zone if it is necessary. The standard width of the TT-slab is 3000mm, height is between 300-1000mm with a spacing of 100mm, and the length can reach up to 24m. The width of the rib is selected according to the load bearing capacity and fire resistance requirement. TT-slabs application enables plenty of indoor space to be saved. The most common TT-slabs are used for industrial and warehouse building roofs. Other applications include large retail buildings and parking buildings, intermediate floors and roofs. The roof slope is provided in applying TT-slabs with HI beams. A typical TT-slab is shown in the figure 18.

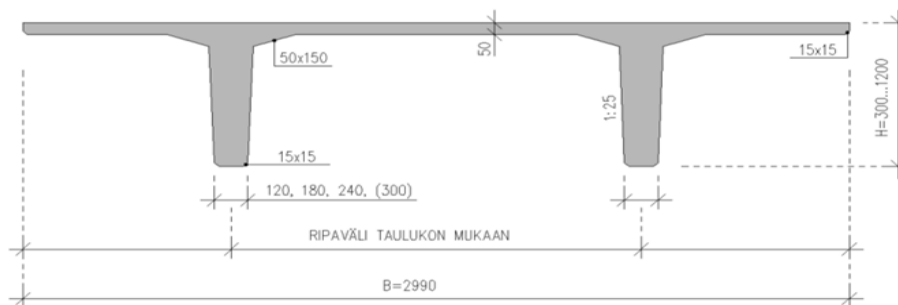
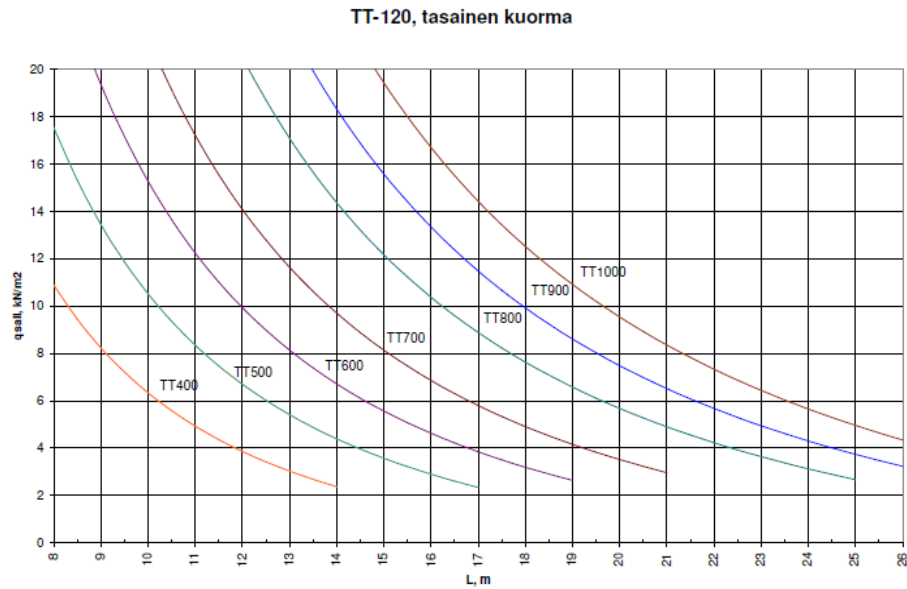

Figure 18 TT-slab (Elementisuunnittelu, TT-laatat)

Table 3 Load bearing capacity curve (Elementisuunnittelu TT-laatat)



As we know in the design of our concrete portal frame, the consequence class is CC2, and the fire resistance class is R60. So table 3 can be used in our roof selection of TT-slab. While acting as a roof element, TT-slabs only need to take snow load which is a vertical distributive load as 2kN/m<sup>2</sup>. So one can realize from the table, no matter how the column spacing of the frame is changing from 6m to 12m, TT400 can be the option for the roof element, 400 means the height of the chosen TT-slab is 400mm, with a rib width of 120mm.

### 4.3 HI-beam

To be able to install TT-slab roof on the structure, we would need roof girders to support it. HI-beam is most commonly unit used in roof system of buildings as main girders. HI-beams are optimized shape such that the material consumption would be small and would work more efficiently with specific cross section. HI-beam can achieve a long span use requirement; the maximum span is 30 meters. The recommendation widths of HI-beams are 380mm and 480mm. In the design, we will follow width of 480mm. A HI-beam is shown in the figure 19.

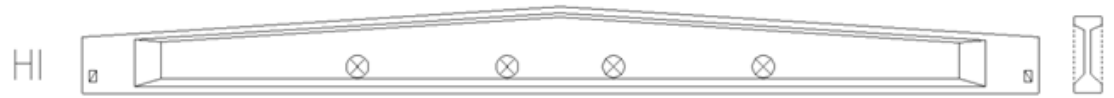
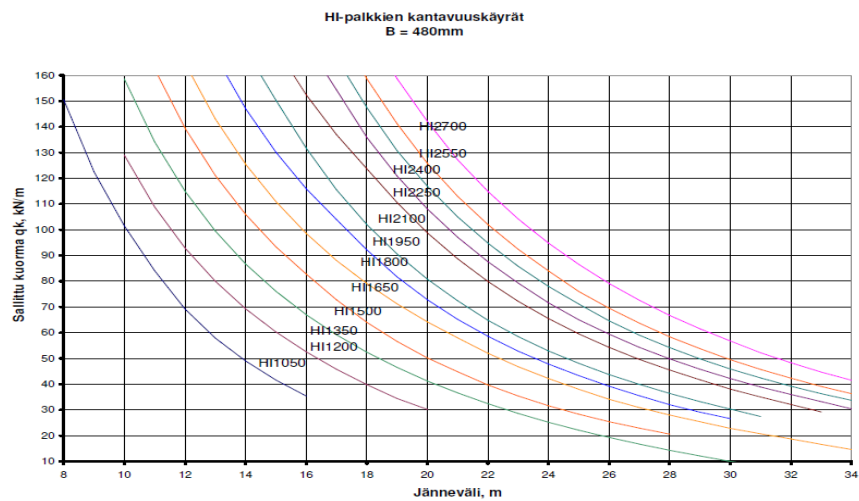

Figure 19 HI-beam([Elementtisuunnittelu.fi/runkorakenteet/palkit/i-ja-hi-palkit](http://Elementtisuunnittelu.fi/runkorakenteet/palkit/i-ja-hi-palkit))

Table 4 Load bearing capacity curve of HI-beams.(  
[Elementtisuunnittelu.fi/runkorakenteet/palkit/i-ja-hi-palkit](http://Elementtisuunnittelu.fi/runkorakenteet/palkit/i-ja-hi-palkit))



With the same frame span of 24m, when we have the column spacing of 12m, the characteristic load value is  $4\text{kN/m}^2 \cdot 12\text{m} = 48\text{kN/m}$ , so we will have HI1950 for the selection. When we have the column spacing of 6m, the characteristic load value is  $4\text{kN/m}^2 \cdot 6\text{m} = 24\text{kN/m}$ , so we will have HI1350 for the selection. The summary distributive loads in terms of roof load and hanging load in the design are  $4\text{kN/m}^2$ . (Calculation can be seen in the appendices 2 and 3.)

#### 4.4 HTT-slab

A HTT-slab roof structure is used for a long-span condition. They are used mainly in industrial and commercial applications. HTT-slabs are 3000 mm wide. The most common gradients are 1:20 and 1:40. The slope of the

ridge depends on the span and the heights ranging from 800mm to 1600mm. A typical HTT-slab is shown in the figure 20.

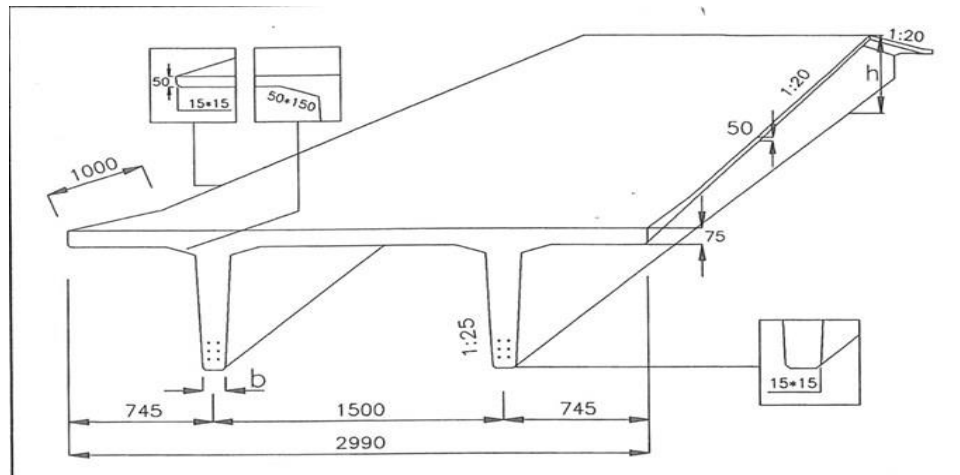
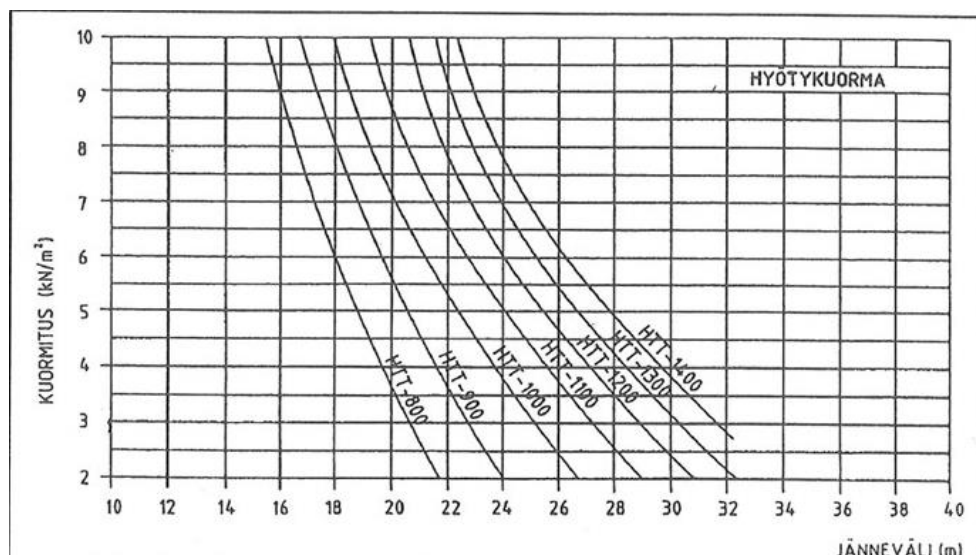

Figure 20 HTT-slab (Elementtisuunnittelu.fi /htt-laatat)

Table 5 Carrying capacity of HTT-slab(Elementtisuunnittelu.fi /htt-laatat)



In the design of our concrete portal frame the span is 24 meters, which gives the gradient of an approximate value of 1:20. Thus, this table is valid

for the design. The snow load on the slab is 2.0kN/m<sup>2</sup>, so HTT-1000 is a suitable selection with a height of 1000mm.

## 5 WALL DESIGN

The wall elements are used in exterior and inner wall panels, partition walls, as well as basement walls. The wall mainly takes the compression force so that stiffening of the wall is always used to resist horizontal loads. Prefabricated walls are made either reinforced or unreinforced. For residential and industrial buildings, the stress is often so small that the walls can be implemented unreinforced in office and commercial buildings, the shear concrete walls can be of plain concrete.

The recommended maximum width of wall panels is 4.2 meters; the maximum length is 8-9 meters. The choice of thickness of the walls is influenced by use, loads, as well as the fire requirement and the sound technical matters. A concrete sandwich wall panel is shown in the figure 21.

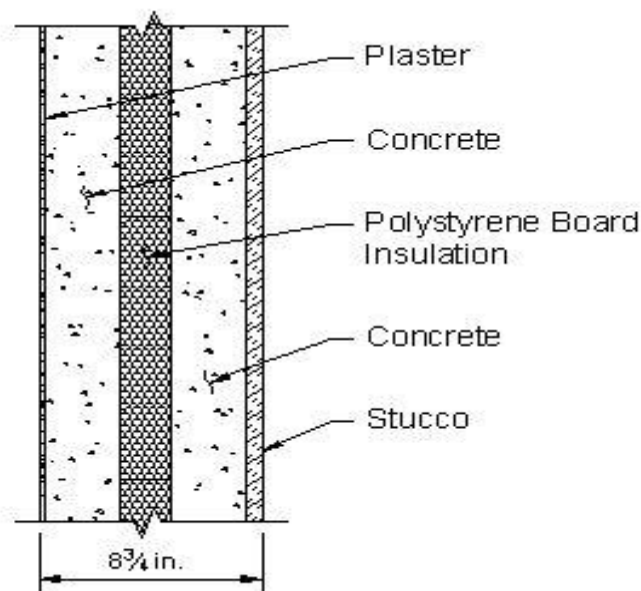

Figure 21 Concrete sandwich wall panel (Concretethinker.com/energymodels)

### 5.1 Concrete sandwich wall

Prefabricated concrete facades have been used commonly in residential and office buildings. A typical concrete sandwich panel consists of three layers: a concrete outer layer, a sandwich layer (thermal insulation layer), and a concrete inner layer. The thickness of the outer layer varies from 70mm to 80mm; the strength of the concrete is about C20/25. The thermal insulation is mineral wool with a thickness of 100 to 160mm depending on the building regulation. The Finnish requirement for thermal conductivity of external wall in regular buildings has been less than 0.17W/Km2 since 2010, which means it requires at least 240mm mineral wool insulation.

Table 6 Concrete sandwich wall panel fire design (Elemensunnitelu,seinat)

Taulukko 5.4 Kantavien <sup>27</sup>betoniseinien vähimmäismitat ja keskiöetäisyyden vähimmäisarvot

Standardi-palonestävyys	Vähimmäismitat (mm)			
	Seinän paksuus / keskiöetäisyys			
	$\mu_e = 0,35$		$\mu_e = 0,7$	
	altistus toiselta puolelta	altistus molemmilta puolin	altistus toiselta puolelta	altistus molemmilta puolin
1	2	3	4	5
REI 30	100/10*	120/10*	120/10*	120/10*
REI 60	110/10*	120/10*	130/10*	140/10*
REI 90	120/20*	140/10*	140/25	170/25
REI 120	150/25	160/25	160/35	220/35
REI 180	180/40	200/45	210/50	270/55
REI 240	230/55	250/55	270/60	350/60

\* Tavallisesti standardin EN 1992-1-1 edellyttämä betonipeitteen paksuus on määräävä.  
Ks. kohdasta 5.3.2 (3) hyväksikäyttöasteen  $\mu_e$  määritelmää.

The fire resistance requirement in our design was R60; the reduction factor for load levels in a fire situation was taken as 0.7 according to the ratio of the vertical design normal force in a fire situation and the design normal force in our case. (See in the appendices 2 and 3, fire resistance design). Hence, we got a minimum dimension of 130mm for concrete walls on one exposed side. Since we had the maximum thickness of 80mm for outer

layer concrete wall, so that we have to add an inner concrete shell with a thickness of 50mm (130-80) to meet the requirement.

## 6 CONCLUSION

The changing of the column spacing has a big influence on the column reinforcement design. In the design process, the usability of a smaller cross section of 280\*280mm of column was also considered, but the result is not promising, for a big second order moment induced by a large slenderness of the columns, unless the span of the frame reduced down to 18 meters and the length of the frame reduced down to 36 meters, which means that in real construction work this could not be done properly because the connected primary HI beams has a minimum width of 380mm which was even bigger than the width of the columns.

The height of hollow-core slabs changes significantly as the spacing changes and the roof systems become lighter and more economical.

TT-slabs do not make a change because in both cases the snow loads are the same, which was the unique load acting on the roof. The selection of HTT-slabs does not change either because the variation is depends on the span of the building which is the same as 24 meters and the same acting distributive load. For the wall structure design, precast concrete sandwich panel have been introduced which finally gives a thickness of 390mm in total, 70mm for outer layer, 240mm for insulation layer, and 80mm for inner shell.



## SOURCES

Balder, 2009. Concise to Eurocode 2. Accessed 28<sup>th</sup> March 2014.

[www.concretecentre.com](http://www.concretecentre.com)

Column, roof, and wall elements design, figures and tables. Accessed 15<sup>th</sup> April 2014.

<http://www.elementtisuunnittelu.fi/>

Concrete sandwich wall. Accessed 2<sup>nd</sup> June 2014.

<http://www.concretethinker.com/energymodels/Residential-Energy-Model-Overview.aspx>

EN1992-1-1 Design of concrete structure. Accessed 1<sup>st</sup> May 2014.

<http://sales.sfs.fi/sfs/servlets/SFSContractServlet?action=enterContract&contractId=10105>

Ilveskoski, 2011. Load combinations sketch, factors tables, frame section plan, floor plan. Accessed 5<sup>th</sup> April 2014.

<https://moodle.hamk.fi/course/view.php?id=5459>

The 3D view of the concrete portal frame. Accessed 20<sup>th</sup> May 2014.

<http://www.archiexpo.com/prod/harrington-precast-concrete/prestressed-reinforced-concrete-portal-frames-59900-238529.html>

Loadings

Dead loads

$g_1 := 3 \frac{\text{kN}}{\text{m}^2}$  The insulated roof generally

$g_2 := 1 \frac{\text{kN}}{\text{m}^2}$  The hanging load

Imposed loads

$q_1 := 2.5 \frac{\text{kN}}{\text{m}^2}$  The snow load on the land

$q_2 := 0.6 \frac{\text{kN}}{\text{m}^2}$  The wind load: terrain category II, the  $h=9\text{m}$

Materials generally

C50/60 Columns and beams

Peak velocity qp

$c_{dir} := 1.0$   $c_{season} := 1.0$   $v_{b0} := 21 \frac{\text{m}}{\text{s}}$

Basic wind velocity  $v_b$   $v_b := c_{dir} \cdot c_{season} \cdot v_{b0} = 21 \frac{\text{m}}{\text{s}}$

Reference height  $z_e$   $z_e$

terraincategory II  $z_0 := 0.05\text{m}$   $z_{min} := 2\text{r}$   $z_{max} := 200\text{r}$

Characteristic peak velocity pressure qp

$z_{0II} := 0.05\text{r}$   $k_r := 0.19 \left( \frac{z_0}{z_{0II}} \right)^{0.07} = 0.19$

$k_1 := 1.0$   $\sigma_v := k_r \cdot v_b \cdot k_1 = 3.99 \frac{\text{m}}{\text{s}}$

Roughness intensity  $cr(z)$

$c_r := k_r \cdot \ln \left( \frac{7}{0.05} \right) = 0.94$

Topography coefficient  $c_0(z)$

$c_0 := 1.0$

$v_m := c_r \cdot c_0 \cdot v_b = 19.72 \frac{\text{m}}{\text{s}}$

Turbulence intensity  $I_v$

$I_v := \frac{\sigma_v}{v_m} = 0.2$   $\rho := 1.25 \frac{\text{kg}}{\text{m}^3}$  1

$q_p := \left( 1 + 7 \cdot I_v \right) \cdot \left( \frac{1}{2} \right) \cdot \rho \cdot v_m^2 = 0.59 \frac{\text{kN}}{\text{m}^2}$

The basic information

The wind velocity  $v_0 := 21 \frac{\text{m}}{\text{s}}$        $\rho := 1.25 \frac{\text{kg}}{\text{m}^3}$

$$q_b := \left(\frac{1}{2}\right) \cdot \rho \cdot v_0^2 = 0.28 \frac{\text{kN}}{\text{m}^2}$$

$c_{dir} := 1.0$        $c_{season} := 1.0$        $c_0 := 1.0$

$c_{scd} := 1.0$        $h < 15\text{m}$

The force coefficient of the long side

$d_1 := 24\text{r}$        $b_1 := 48\text{m}$        $\frac{d_1}{b_1} = 0.5$

$h_c := 7\text{r}$        $\lambda_1 := 2 \cdot \frac{h_c}{b_1} = 0.29$        $c_{f1} := 1.37$

The force coefficient of the short side

$d_2 := 48\text{r}$        $b_2 := 24\text{m}$        $\frac{d_2}{b_2} = 2$

$h_c := 7\text{r}$        $\lambda_2 := 2 \cdot \frac{h_c}{b_2} = 0.58$

$c_{f2} := 0.99$

The wind pressure, terrain class II, the height 7m

$c_{ez} := 2.2$        $q_p := c_{ez} \cdot q_b = 0.61 \frac{\text{kN}}{\text{m}^2}$

The total wind loads with the force confident

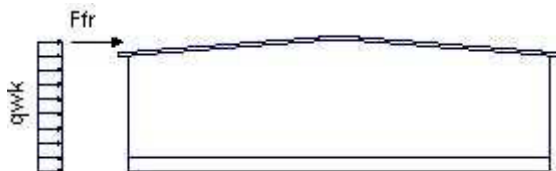

The total wind load of the long side

$$F_{w1} := c_{scd} \cdot c_{f1} \cdot q_p \cdot 7\text{m} \cdot 48\text{m} = 279.13\text{kN}$$

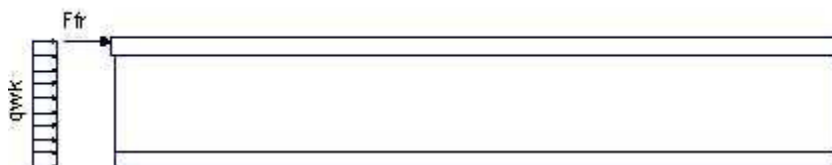

The total wind load of the end

$$F_{w2} := c_{scd} \cdot c_{f2} \cdot q_p \cdot 7\text{m} \cdot 24\text{m} = 100.85\text{kN}$$

Friction coefficient

$$c_{fr} := 0.0$$

$$F_{fr} := qp \cdot c_{fr} \cdot (38m \cdot 20m) = 9.22kN$$

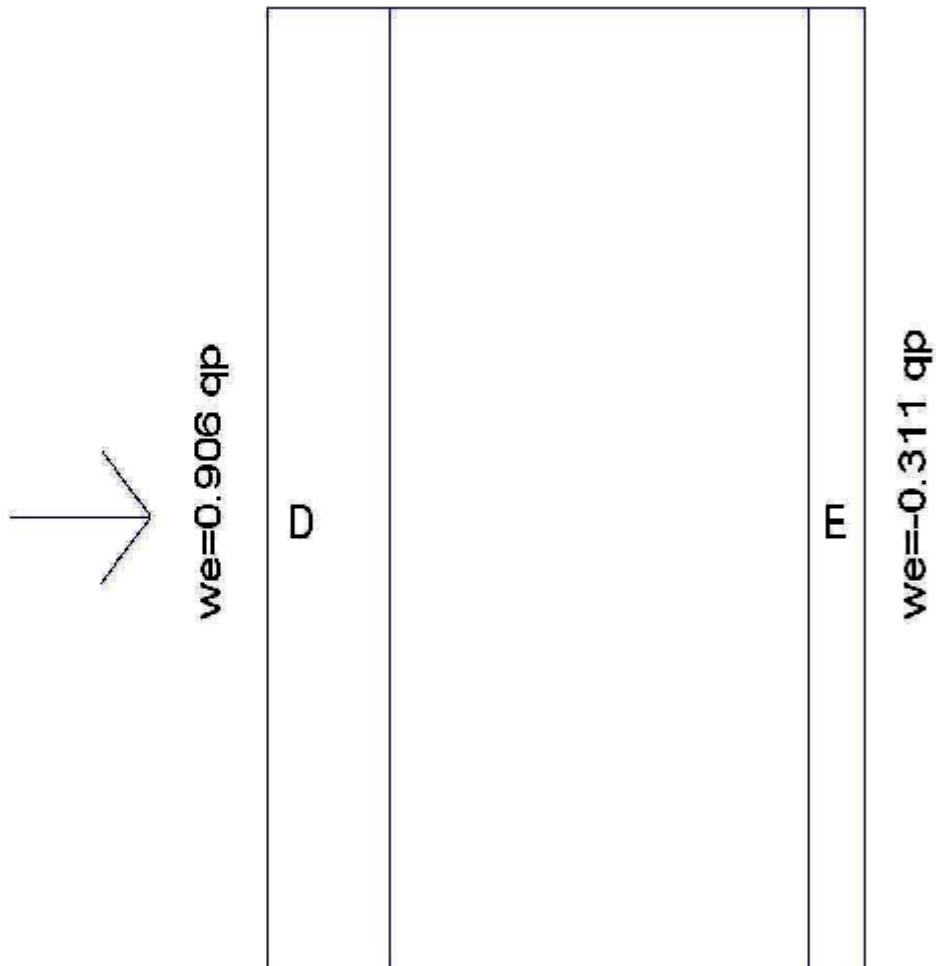

The total wind load in one direction calculated with the partial pressure values.

The total wind load calculated with partial pressure areas:

$$A_{ref} := 7m \cdot 48m = 336m^2$$

$$F_w := (0.906 + 0.311) \cdot qp \cdot A_{ref} = 247.95kN$$

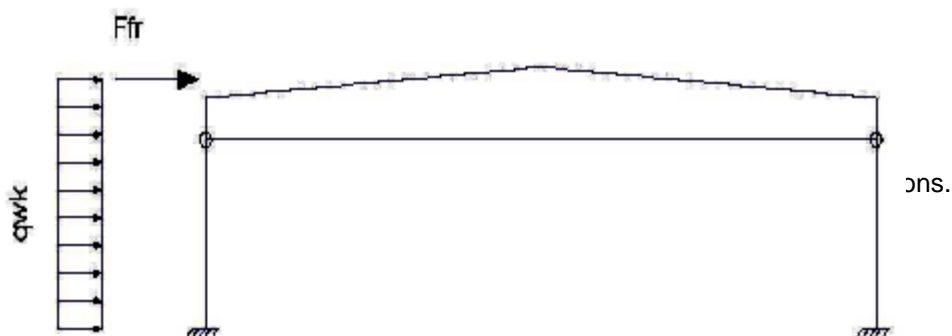

The imperfections

$\phi_0 := \frac{1}{200}$  Basic imperfection value, which is changed according To the total height and figure of the frame.

$a_h := \frac{2}{\sqrt{7}} = 0.76$  The decrease coefficient of the height when h = 7m

$a_m := \sqrt{0.5 \left(1 + \frac{1}{2}\right)} = 0.87$  The decrease coefficient of the following columns.

$\phi := \phi_0 \cdot a_h \cdot a_m = 3.27 \times 10^{-3}$  The imperfection from the vertical line causes additions To the forces

In the structural analysis the imperfections are included by adding the equivalent forces in the frame corners, which are relative to the imperfections and the normal forces.

Load combinations

		Perm	Wind	Snow	
		$\psi_0$	$\psi_0$	l	r
	LC	$\psi_0$	$\psi_0$	$\psi_0$	$\psi_0$
G	1	1	0	0	0
WIND	2	1	1	0	0
	3	1	1	0.7	0.7
	4	1	1	0.7	0.35
	5	1	1	0.35	0.7
SNOW	6	1	0	1	1
	7	1	0.6	1	1
SNOW	L	8	1	0	1
		9	1	0.6	1
	R	10	1	0	0.5
		11	1	0.6	0.5

Partial safety factors

$\gamma_G := 1.1$ : Permanent loads

$\gamma_{Gmax} := 1.3$ : Permanent loads

$\gamma_{Gmin} := 0.9$ : Permanent loads

$\gamma_Q := 1.5$ : Imposed loads

$\psi_0 := 0.7$ : Snow

$\psi_0 := 0.6$ : Wind



The cantilever column is designed for the load combination LC3:

$$LC\ 3: \quad \gamma_G \cdot K_{f1} \cdot G_{kj} \text{ (dead load)} + \gamma_{Q,1} \cdot K_{f1} \cdot Q_{kj} \text{ (wind)} + \gamma_{Q,1} \cdot K_{f1} \cdot \sum \psi_{0j} \cdot Q_{ki} \text{ (snow)} = \\ 1.15 \cdot 1 \cdot G_{kj} \text{ (dead load)} + 1.5 \cdot 1 \cdot Q_{kj} \text{ (wind)} + 1.5 \cdot 1 \cdot \sum 0.7 \cdot Q_{ki} \text{ (snow)}$$

$s := 6\text{m}$	Frame spacing
$B := 24\text{m}$	Breath of the frame
$H := 6.75\text{m}$	Building height
$L := 6\text{m}$	Column height

The roof loads:

$gk_1 := 3 \frac{\text{kN}}{\text{m}^2}$	roof
$gk_2 := 1 \frac{\text{kN}}{\text{m}^2}$	Hanging loads
$gk_3 := 10 \frac{\text{kN}}{\text{m}}$	HI - prestressed beam

Snow load

$qk_1 := 2 \frac{\text{kN}}{\text{m}^2}$	snow
--	------

Wind load

$q_p = 0.61 \frac{\text{kN}}{\text{m}^2}$	wind
$c_{scd} := 1.0$	Wind coefficient
$c_f := 1.3'$	Wind force factor

$$\phi := \frac{1}{305}$$

$$Nd_3 := \left[ 1.15 \cdot (gk_1 + gk_2) + 1.5 \cdot 0.7 qk_1 \right] \cdot s \cdot \frac{B}{2} + 1.15 \cdot gk_3 \cdot \left( \frac{B}{2} \right) = 620.4 \cdot \text{kN}$$

$$q_{wd} := 1.5 \cdot c_{scd} \cdot c_f \cdot q_p \cdot s = 7.48 \cdot \frac{\text{kN}}{\text{m}}$$

$$H := 6.75\text{m} \quad L = 6\text{m} \quad \left( \sum gk_1 + gk_2 + qk_1 \right) \cdot s \cdot \frac{B}{2} + gk_3 \cdot \frac{B}{2} = 552 \cdot \text{kN}$$

$$F_{wd} := q_{wd} \cdot (H - L) = 5.61 \text{kN}$$

Imperfections

$$\phi = 3.28 \times 10^{-3}$$

$$H_{eq} := 2 \cdot \phi \cdot Nd_3 = 4.07 \text{ kN}$$

$$Md_3 := \frac{5 \cdot q_{wd} \cdot L^2}{16} + \frac{F_{wd} \cdot L}{2} + \frac{H_{eq} \cdot L}{2} = 113.14 \text{ kNm}$$

The wind friction force is shared to the cantilever columns.

The column design with the nominal curvature method. (EC2, 5.5.8)

Column height

$$L := 6 \text{ m}$$

Section

$$b := 380 \text{ mm} \quad h := 380 \text{ mm}$$

Concrete C40/50 -1

$$f_{cd} := \left( \frac{0.8540}{1.35} \right) \cdot \frac{\text{N}}{\text{mm}^2} = 25.19 \frac{\text{N}}{\text{mm}^2}$$

Steel A500HW

$$f_{yd} := \left( \frac{500}{1.1} \right) \cdot \frac{\text{N}}{\text{mm}^2} = 454.55 \frac{\text{N}}{\text{mm}^2}$$

Concrete age

28 days

concrete age with loading

$$E_s := 2 \cdot 10^5 \cdot \frac{\text{N}}{\text{mm}^2}$$

Exposure class XC1

## 2. First order forces

Loads:

$$N_{0Ed} := Nd_3 = 620.4 \text{ kN}$$

$$M_d := Md_3 = 113.14 \text{ kNm}$$

Imperfection included

$$M_{0Eqp} := 7 \text{ kNm}$$

Imperfections

$$\alpha_h := \frac{2}{\sqrt{7}} = 0.76 \quad \alpha_m := \sqrt{0.5 \left(1 + \frac{1}{2}\right)} = 0.87$$

$$\phi_0 := \frac{1}{200} = 5 \times 10^{-3}$$

$$\phi_i := \phi_0 \cdot \alpha_h \cdot \alpha_m = 3.27 \times 10^{-3}$$

$$L := 6m \quad L_0 := 2.186m = 13.08m$$

$$e_i := \max\left(\phi_i \cdot \frac{L_0}{2}, \frac{h}{30}, 20mm\right) \quad e_i := 2mm$$

First order forces  $N_{0Ed}$   $M_{0Ed}$

$$N_{0Ed} = 6.2 \times 10^5 N$$

$$M_{01} := N_{0Ed} \cdot \frac{\phi_i}{2} \cdot L_0 = 13.28 kNm$$

$$M_{02} := M_d = 113.14 kNm$$

$$M_{0Ed} := M_{02} = 113.14 kNm$$

### 3. Buckling length

Creep

$$RH := 50 \quad u := 2 \cdot (b + h) = 1.52m \quad A_c := b \cdot h = 0.14m^2$$

$$h_o := \frac{(2 \cdot A_c)}{u} = 190mm$$

$$\phi_{rh} := \left[ 1 + \frac{\left[ 1 - \left( \frac{RH}{100} \right) \right]}{\frac{1}{0.1140^3}} \cdot \left( \frac{35}{58} \right)^{0.7} \right] \cdot \left( \frac{35}{58} \right)^{0.2} = 1.52$$

$$f_{cm} := 58MPa \quad \beta_{f_{cm}} := \frac{16.8}{\sqrt{58}} = 2.21$$

$$t_o := 28 \quad \beta_{t_o} := \left[ \frac{1}{(0.1 + t_o^{0.2})} \right] = 0.49$$

$$\phi_o := \phi_{rh} \cdot \beta_{f_{cm}} \cdot \beta_{t_o} = 1.63$$

Limit value of the buckling length

$$\varphi_{ef} := \phi_o \cdot \frac{M_{0Eqp}}{M_{0Ed}} = 1.13 \quad A_c := b \cdot h = 0.14m^2$$

$$A := \frac{1}{(1 + 0.2\varphi_{ef})} = 0.82$$

$$A_s := 4 \cdot \pi \cdot (12.5mm)^2 = 1.96 \times 10^{-3} m^2$$



$$\omega := \frac{(A_s \cdot f_{yd})}{A_c \cdot f_{cd}} = 0.25$$

$$B := \sqrt{1 + 2 \cdot \omega} = 1.22$$

$$r_m := \frac{M_{01}}{M_{02}} = 0.12 \quad C := 0.7 \quad \text{For unbraced column}$$

$$N_{Ed} := N_{0Ed} = 620.4 \text{ kN} \quad n := \frac{N_{Ed}}{A_c \cdot f_{cd}} = 0.17$$

$$\lambda_{lim} := \frac{20A \cdot B \cdot 0.7}{\sqrt{n}} = 33.78$$

Buckling length  $L := 6000 \text{ mm}$

$$k_1 := 0.1 \quad k_2 := 10^6 \quad L_0 := 2.18L = 1.31 \times 10^4 \text{ mm}$$

$$h := 380 \text{ mm}$$

$$\lambda := \frac{L_0}{0.289h} = 119.1 \quad \text{Which is bigger than } \lambda_{lim}$$

Second order forces must be included.

#### 4. Second order forces

Exposure class XC2

Minimum cover due to bond anchoring

$$c_{min,b} := 32 \text{ mm}$$

Minimum cover due to environmental conditions

$$c_{min,dur} := 20 \text{ mm} - 5 \text{ mm} = 15 \text{ mm}$$

Addictive safety element

$$c_{dur,\gamma} := 0$$

Reduction for use of additions

$$c_{dur,add} := C$$

$$c_{dur,st} := C$$

$$c_{min} := \max(c_{min,b}, c_{min,dur} + c_{dur,\gamma} - c_{dur,st} - c_{dur,add}, 10 \text{ mm})$$

$$c_{min} := 32 \text{ mm}$$

$$c_{dev} := 10 \text{ mm}$$

$$c_{nom} := c_{min} + c_{dev} = 0.04 \text{ m}$$

$$d := h - c_{nom} = 0.34 \text{ m}$$

8

$$n_{bal} := 0 \leq \left[ \frac{(n_u - n)}{(n_u - n_{bal})}, 1 \right] := 1 + \omega = 1.25$$

$$K_T := \min \left[ \frac{(n_u - n)}{(n_u - n_{bal})}, 1 \right] \quad K_T := 1$$

$$f_{ck} := 50 \frac{\text{N}}{\text{mm}^2} \quad \beta := 0.35 + \frac{50}{200} - \frac{\lambda}{150} = -0.19$$

$$\varphi_{ef} := 1.12$$

$$K_{\varphi} := \max\left[\left(1 + \beta \cdot \varphi_{ef}\right), 1\right] \quad K_{\varphi} := 1$$

$$f_{yd} := 4.54510^8 \text{P}\varepsilon \quad E_s := 2 \cdot 10^5 \cdot \frac{\text{N}}{\text{mm}^2} \quad d := 338\text{mm}$$

$$e_2 := 0.1 \left[ \frac{(K_T \cdot K_{\varphi} \cdot f_{yd}) \cdot (L_0^2)}{0.45d \cdot E_s} \right] = 0.26\text{m}$$

$$M_2 := N_{0Ed} e_2 = 158.58\text{kNr}$$

### 5. Section design

$$M_{01} := N_{0Ed} \frac{\phi_i}{2} \cdot L_0 = 13.28\text{kNr}$$

$$M_{02} := M_d = 113.14\text{kNr}$$

$$M_{Ed} := M_{02} + M_2 = 271.72\text{kNr}$$

$$\nu := \frac{N_{0Ed}}{A_c \cdot f_{cd}} = 0.17$$

$$\mu := \frac{M_{Ed}}{b \cdot h^2 \cdot f_{cd}} = 0.2$$

$$\omega_{tot} := 0.4$$

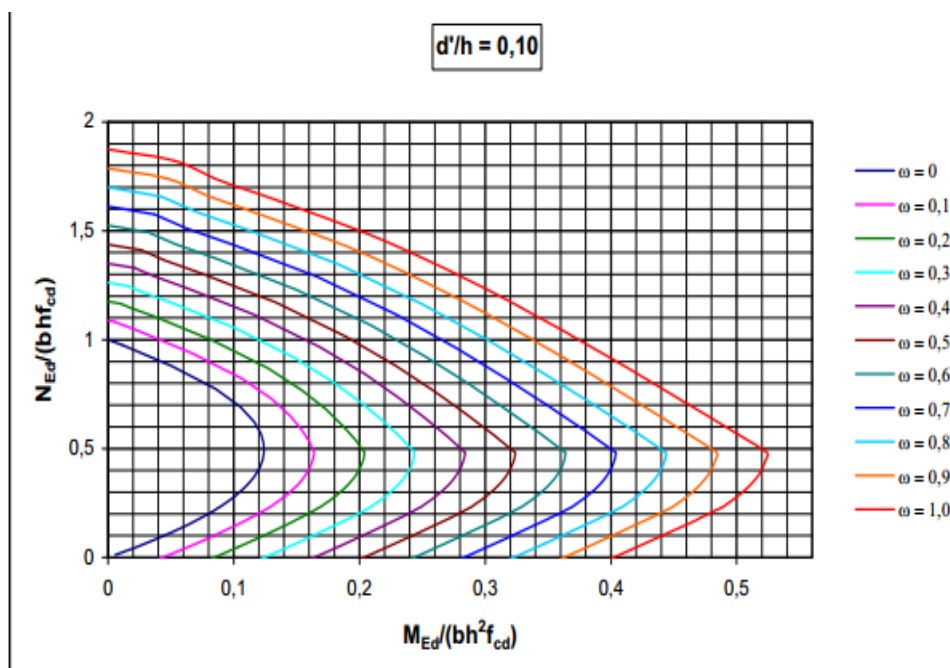

$$f_{cd} := 31.5 \frac{N}{mm^2} \qquad f_{yd} := 455 \frac{N}{mm^2}$$

$$A_s := \omega_{tot} \left( \frac{f_{cd}}{f_{yd}} \right) \cdot b \cdot h = 4 \times 10^3 \cdot mm^2$$

One side needs 2000 mm<sup>2</sup>, let's choose T25 rebar

$$4 \pi \cdot (12.5mm)^2 = 1.96 \times 10^{-3} m^2$$

The maximum and minimum reinforcement areas of the column:

$$A_{smin} := \max \left( 0.1 \frac{N_{Ed}}{f_{yd}}, 0.002 A_c \right) \qquad A_{smin} := 289 mm^2$$

$$A_{smax} := 0.06 A_c = 8.66 \times 10^3 \cdot mm^2$$

Stirrups

Stirrup's minimum diameter include 6mm or 0.25\* main reinforcement

Let us choose T8 stirrups

Stirrups spacing max 15\*

The end wall's corner column

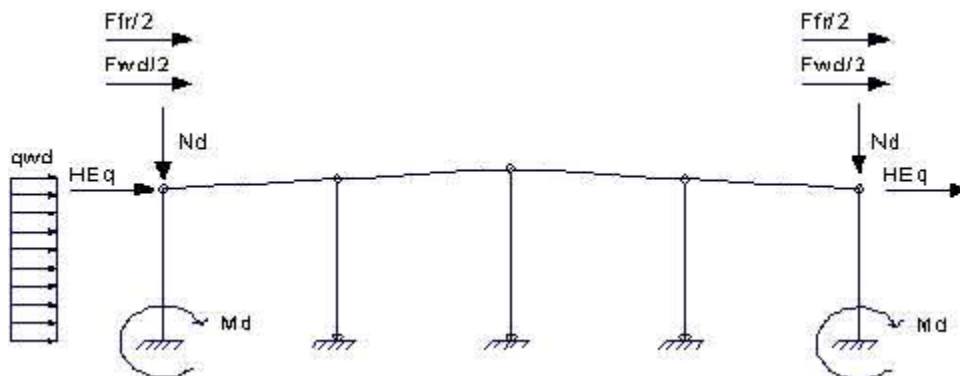

$$LC\ 3: G\ Kf1\ Gkj\ (\text{dead load}) + Q,\ 1\ Kf1\ Qkj\ (\text{wind}) + Q,\ 1\ Kf1\ 0jQki\ (\text{snow}) = 1.15 * 1 * Gkj\ (\text{dead load}) + 1.5 * 1 * Qkj\ (\text{wind}) + 1.5 * 1 * 0.7\ Qki\ (\text{snow})$$

$$s := 6m$$

Frame spacing

$$B := 24m$$

Breath of the frame

$$H := 6.75m$$

Building height

$$L := 6m$$

Column height

The roof loads:

$$gk_1 := 3 \frac{\text{kN}}{\text{m}^2} \quad \text{roof}$$

$$gk_2 := 1 \frac{\text{kN}}{\text{m}^2} \quad \text{Hanging loads}$$

$$gk_3 := 10 \frac{\text{kN}}{\text{m}} \quad \text{HI - prestressed beam}$$

Snow load

$$qk_1 := 2 \frac{\text{kN}}{\text{m}^2} \quad \text{snow}$$

Wind load

$$qp = 0.61 \frac{\text{kN}}{\text{m}^2} \quad \text{wind}$$

$$cscd := 1.0 \quad \text{Wind coefficient}$$

$$c_f := 1.3' \quad \text{Wind force factor}$$

$$N_d := \left[ 1.15 \cdot (gk_1 + gk_2) + 1.5 \cdot 1.0 \cdot qk_1 \right] \cdot \frac{s}{2} \cdot \frac{B}{4} = 136.8 \text{ kN}$$

Eave forces

$$q_{wd} := 1.5 \cdot cscd \cdot c_f \cdot qp \cdot \frac{s}{2} = 3.74 \text{ m} \cdot \frac{\text{kN}}{\text{m}^2}$$

$$H := 7 \text{ m} \quad L := 6 \text{ m}$$

$$F_{wd} := q_{wd} \cdot (H - L) = 3.74 \text{ kN}$$

Imperfection

$$\phi := \frac{1}{305}$$

$$H_{eq} := 2 \cdot \phi \cdot N_d = 0.9 \text{ kN}$$

$$M_d := \frac{5 \cdot q_{wd} \cdot L^2}{16} + \frac{F_{wd} \cdot L}{2} + \frac{H_{eq} \cdot L}{2} = 55.96 \text{ kNm}$$

The wind column

The end wall's wind column is designed for the load combination LC3

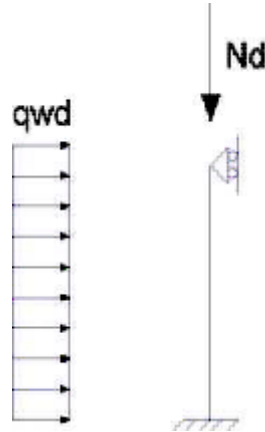

$$LC\ 3: G\ Kf1\ Gkj\ (\text{dead load}) + Q,1\ Kf1\ Qkj\ (\text{wind}) + Q,1\ Kf1\ 0jQki\ (\text{snow}) = 1.15 * 1 * Gkj\ (\text{dead load}) + 1.5 * 1 * Qkj\ (\text{wind}) + 1.5 * 1 * 0.7\ Qki\ (\text{snow})$$

$s := 6m$	Frame spacing
$B := 24m$	Breath of the frame
$H := 6.75m$	Building height
$L := 6m$	Column height

The roof loads:

$gk_1 := 3 \frac{kN}{m^2}$	roof
$gk_2 := 1 \frac{kN}{m^2}$	Hanging loads
$gk_3 := 10 \frac{kN}{m}$	HI - prestressed beam

Snow load

$qk_1 := 2 \frac{kN}{m^2}$	snow
----------------------------	------

Wind load

$qp = 0.61 \frac{kN}{m^2}$	wind
----------------------------	------

$cscd := 1.0$	12	Wind coefficient
---------------	----	------------------

$cf := 0.9$		Wind force factor against the wall
-------------	--	------------------------------------

$$N_{dw} := \left[ 1.15 \cdot (gk_1 + gk_2) + 1.5 \cdot 0.7 \cdot qk_1 \right] \cdot \frac{s}{2} \cdot \frac{B}{4} = 120.6 \text{ kN}$$

$$q_{wd} := 1.5 \cdot cscd \cdot c_f \cdot \frac{B}{4} \cdot qp = 4.91 \cdot \frac{\text{kN}}{\text{m}}$$

$$M_{dw} := \frac{q_{wd} \cdot L^2}{8} = 22.1 \text{ kNm}$$

$$V_d := \left( \frac{5}{8} \right) \cdot q_{wd} \cdot L = 18.42 \text{ kN}$$

The end wall's columns are assumed as having fixed bottom connections. The Columns are designed as cantilever columns supported at their top connections.

The fire design of the cantilever column

The section design in fire, R60

The forces and bending moments in fire  $N_{Edfi}$  and  $M_{0Edfi}$

The second order forces are included in the capacity curves.

$$N_{Edfi} := 436.8 \text{ kN} \quad M_{0Edfi} := 25.6 \text{ kNm}$$

$$b := 380 \text{ mm} \quad h := 380 \text{ mm} \quad f_{cd} = 3.15 \times 10^7 \text{ Pa}$$

$$v_{fi} := \frac{N_{Edfi}}{b \cdot h \cdot f_{cd}} = 0.1$$

$$\mu_{fi} := \frac{M_{0Edfi}}{N_{Edfi} \cdot h} = 0.01$$

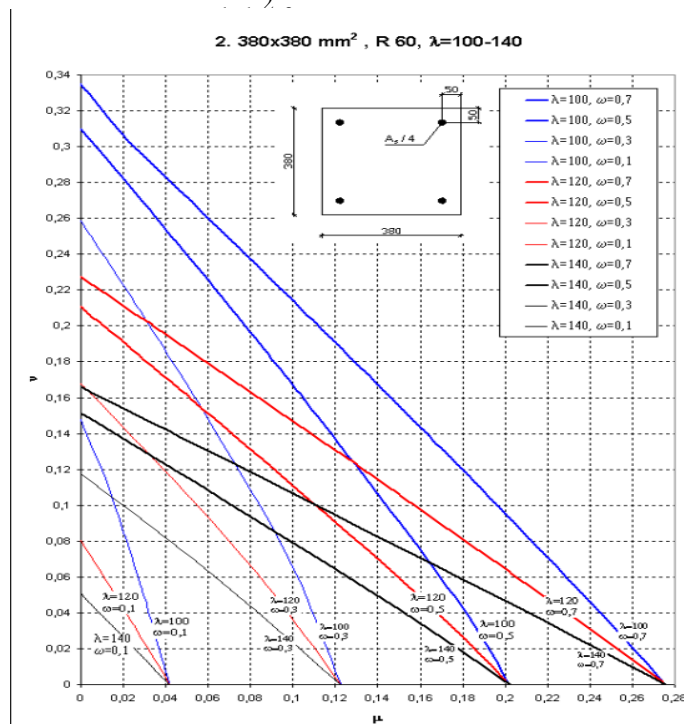

Because the column in our case Has same section height with column section 380\*380, so we can Consider they share the same diagram.

$$w_f := 0.4 \quad w_{tot} := 0.4$$

The mechanical reinforcement ratio In the normal temperature is  $\omega = 0.5$  Which is bigger than the value in fire, which means that the column 280\*380mm,  $a=50$ mm, has enough Capacity in the fire class R60

## PAD FOUNDATION

The column loads:

$$\text{Transverse direction: } N_{d1} := 620.4 \text{ kN} \quad M_{d1} := M_{Ed} = 271.72 \text{ kNm}$$

$$N_{k1} := 552 \text{ kN} \quad M_{k1} := 236.733 \text{ kNm}$$

Longitudinal direction:

$$N_{d2} := 620.4 \text{ kN} \quad M_{d2} := 2 \text{ kNm}$$

$$N_{k2} := 552 \text{ kN} \quad M_{k2} := 14.7 \text{ kNm}$$

The pad size 2.8\*1.2\*0.6m<sup>3</sup>

Floor design load :( storage load slab)

$$N_{d3} := (1.51 \cdot 7.5 + 1.150 \cdot 1525) \cdot 2.81.2 \text{ kN} = 52.29 \text{ kN}$$

$$N_{k3} := (1 \cdot 7.5 + 1 \cdot 0.1525) \cdot 2.81.2 \text{ kN} = 37.8 \text{ kN}$$

Truck load

$$Q_{dT} := 1.51 \cdot 1.44 \text{ kN} = 84 \text{ kN} \quad N_{d4} := 84 \text{ kN}$$

$$N_{k4} := 1 \cdot 1 \cdot 1.44 \text{ kN} = 56 \text{ kN}$$

Extra truck load moment

$$M_{d3} := 100 \text{ kNm}$$

$$M_{k3} := 57 \text{ kNm}$$

Pad and fill load:

$$N_{d5} := (1.150 \cdot 420 + 1.150 \cdot 625) \cdot 2.81.2 \text{ kN} = 88.87 \text{ kN}$$

$$N_{k5} := (1 \cdot 0.420 + 1 \cdot 0.625) \cdot 2.81.2 \text{ kN} = 77.28 \text{ kN}$$

Pad transverse design load

$$N_{dps} := N_{d1} + N_{d3} + N_{d4} + N_{d5} = 845.56 \text{ kN}$$

$$M_{dps} := M_{d1} + M_{d3} = 371.72 \text{ kNm}$$

$$M_{kps} := M_{k1} + M_{k3} = 293.73 \text{ kNm}$$

Pad longitudinal design load

$$N_{dpp} := N_{d2} + N_{d3} + N_{d4} + N_{d5} = 845.56 \text{ kN}$$

$$M_{dpp} := M_{d2} + M_{d3} = 122 \text{ kNm}$$

$$M_{kpp} := M_{k2} + M_{k3} = 71.7 \text{ kNm}$$

The column on ground pad

Loadings

$$N_{MyEd} := 100 \text{ kN} \quad M_{yEd} := 37 \text{ kNm} \quad N_{MyEk} := 55 \text{ kN} \quad M_{yEk} := 29 \text{ kNm}$$

$$N_{MxEEd} := 100 \text{ kN} \quad M_{xEEd} := 12 \text{ kNm} \quad N_{MxEk} := 55 \text{ kN} \quad M_{xEk} := 7 \text{ kNm}$$

Concrete C30/37

$$\gamma_c := 1.5 \quad \alpha := 0.85 \quad \alpha_{ct} := 1.0 \quad f_{ck} := 30 \frac{\text{N}}{\text{mm}^2} \quad f_{ck2} := 30$$

$$f_{cd} := \frac{(\alpha \cdot f_{ck})}{\gamma_c} = 1.7 \times 10^7 \text{ Pa} \quad f_{cm} := f_{ck} + 8 \cdot \frac{\text{N}}{\text{mm}^2} = 3.8 \times 10^7 \text{ Pa}$$

$$f_{ctm} := 0.3 f_{ck2}^{\frac{2}{3}} \cdot \frac{\text{N}}{\text{mm}^2} = 2.9 \times 10^6 \text{ Pa} \quad f_{ctk005} := 0.7 f_{ctm} = 2.03 \times 10^6 \text{ Pa}$$

$$f_{ctd} := \left( \alpha_{ct} \cdot \frac{f_{ctk005}}{\gamma_c} \right) = 1.35 \times 10^6 \text{ Pa}$$

Steel

$$\gamma_s := 1.1 \quad f_{yk} := 500 \frac{\text{N}}{\text{mm}^2} \quad f_{yd} := \frac{f_{yk}}{\gamma_s} = 4.35 \times 10^8 \text{ Pa}$$

Basic data

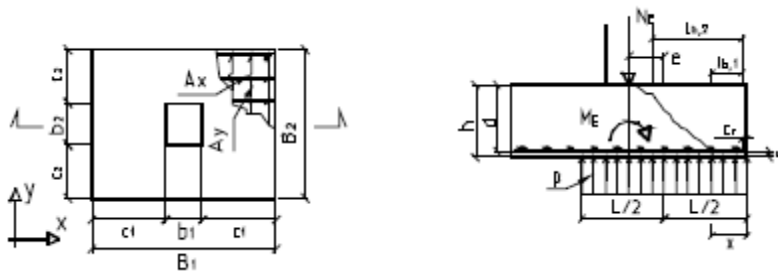

$$B_1 := 280 \text{ mm} \quad B_2 := 200 \text{ mm} \quad h := 600 \text{ mm} \quad c := 50 \text{ mm} \quad c_1 := 50 \text{ mm}$$

$$b_1 := 380 \text{ mm} \quad b_2 := 280 \text{ mm} \quad T_{sx} := 16 \text{ mm} \quad T_{sy} := 16 \text{ mm}$$

$$d_x := h - c - \frac{T_{sx}}{2} = 0.54 \text{ m} \quad d_y := h - c - \left( T_{sx} + \frac{T_{sy}}{2} \right) = 0.53 \text{ m}$$

$$c_1 := \frac{(B_1 - b_1)}{2} = 1.2 \text{ m} \quad c_2 := \frac{(B_2 - b_2)}{2} = 0.86 \text{ m}$$

Data limits

$$B_1 \leq b_1 + 6 \cdot d_x = 1 \quad B_1 \geq b_1 + 2 \cdot d_x = 1$$

$$B_2 \leq b_2 + 6 \cdot d_y = 1 \quad B_2 \geq b_2 + 2 \cdot d_y = 1$$



Capacity  $R_{dA} := 250 \frac{\text{kN}}{\text{m}^2}$

Foundation dead load, reinforcement design

$\rho_c := 25 \frac{\text{kN}}{\text{m}^3}$   $G_{fEd} := 1.15 B_1 \cdot B_2 \cdot h \cdot \rho_c = 96.6 \text{ kN}$

Foundation dead load, EQU

$G_{fEd2} := 0.9 B_1 \cdot B_2 \cdot h \cdot \rho_c = 75.6 \text{ kN}$

$G_{fEk} := 1.0 B_1 \cdot B_2 \cdot h \cdot \rho_c = 84 \text{ kN}$

Foundation stress

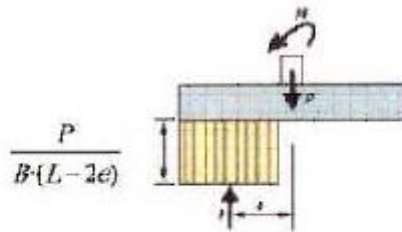

Kuva 2 Pilarianturan pohjapainejakauma STR ja GEO tarkasteluissa

Moment y-axis

$e_{xd} := \frac{M_{yEd}}{(N_{MyEd} + G_{fEd})} = 0.34 \text{ m}$

$e_{xk} := \frac{M_{yEk}}{(N_{MyEk} + G_{fEk})} = 0.46 \text{ m}$

$L_{xd} := B_1 - 2 \cdot e_{xd} = 2.12 \text{ m}$

$L_{xk} := B_1 - 2 \cdot e_{xk} = 1.88 \text{ m}$

$p_{xE d} := \frac{(N_{MyEd} + G_{fEd})}{B_2 \cdot L_{xd}} = 258.44 \frac{\text{kN}}{\text{m}^2}$

$p_{xE k} := \frac{(N_{MyEk} + G_{fEk})}{B_2 \cdot L_{xk}} = 169.56 \frac{\text{kN}}{\text{m}^2}$

Moment x-axis

$e_{yd} := \frac{M_{xE d}}{(N_{MxE d} + G_{fEd})} = 0.11 \text{ m}$

$e_{yk} := \frac{M_{yEk}}{(N_{MyEk} + G_{fEk})} = 0.46 \text{ m}$

$L_{yd} := B_1 - 2 \cdot e_{xd} = 2.12 \text{ m}$

$L_{yk} := B_1 - 2 \cdot e_{xk} = 1.88 \text{ m}$

$p_{yE d} := \frac{(N_{MxE d} + G_{fEd})}{B_1 \cdot L_{yd}} = 184.6 \frac{\text{kN}}{\text{m}^2}$

$p_{yE k} := \frac{(N_{MxE k} + G_{fEk})}{B_1 \cdot L_{yk}} = 121.11 \frac{\text{kN}}{\text{m}^2}$

Reinforcement

$A_{sx} := 17 \pi \cdot \frac{T_{sx}^2}{4} = 3.42 \times 10^3 \cdot \text{mm}^2$

$A_{sy} := 17 \pi \cdot \frac{T_{sy}^2}{4} = 3.42 \times 10^3 \cdot \text{mm}^2$

SLS moment y-axis:

$$M_{yik} := 0.5 p_{xEk} B_2 \cdot c_1^2 = 248.25 \text{ kNm}$$

$$\mu_{xik} := \frac{M_{yik}}{B_2 \cdot f_{cd} \cdot d_x^2} = 0.02$$

$$\beta_{xik} := 1 - \sqrt{1 - 2 \cdot \mu_{xik}} = 0.03$$

$$z_{xik} := d_x \cdot \left(1 - \frac{\beta_{xik}}{2}\right) = 0.54 \text{ m}$$

$$F_{xikt} := \frac{M_{yik}}{z_{xik}} = 463.86 \text{ kN}$$

$$\sigma_{xsk} := \frac{M_{yik}}{A_{sxp} \cdot z_{xik}} = 135.71 \frac{\text{N}}{\text{mm}^2}$$

ULS moment x-axis:

$$M_{xid} := 0.5 p_{yEd} B_1 \cdot c_2^2 = 191.15 \text{ kNm}$$

$$\mu_{yid} := \frac{M_{xid}}{B_1 \cdot f_{cd} \cdot d_y^2} = 0.01$$

$$\beta_{yid} := 1 - \sqrt{1 - 2 \cdot \mu_{yid}} = 0.01$$

$$z_{yid} := d_y \cdot \left(1 - \frac{\beta_{yid}}{2}\right) = 0.52 \text{ m}$$

$$A_{svaady} := \frac{M_{xid}}{z_{yid} \cdot f_{yd}} = 841.96 \text{ mm}^2$$

$$A_{sminy} := \max \left[ 0.26 \left( \frac{f_{ctm}}{f_{yk}} \right) \cdot B_1 \cdot d_y, 0.0013 B_1 \cdot d_y, 0.2 A_{sx} \right] = 2.22 \times 10^3 \cdot \text{mm}^2$$

$$A_{syprov} := \max(A_{sy}, A_{svaady}, A_{sminy}) = 3.42 \times 10^3 \cdot \text{mm}^2$$

SLS moment y-axis:

$$M_{xik} := 0.5 p_{yEk} B_1 \cdot c_2^2 = 125.4 \text{ kNm}$$

$$\mu_{yik} := \frac{M_{xik}}{B_2 \cdot f_{cd} \cdot d_y^2} = 0.01$$

$$\beta_{yik} := 1 - \sqrt{1 - 2 \cdot \mu_{yik}} = 0.01$$

$$z_{yik} := d_y \cdot \left(1 - \frac{\beta_{yik}}{2}\right) = 0.52 \text{ m}$$

$$F_{yikt} := \frac{M_{xik}}{z_{yik}} = 240.02 \text{ kN}$$

$$\sigma_{ysk} := \frac{M_{xik}}{A_{syprov} \cdot z_{yik}} = 70.22 \frac{\text{N}}{\text{mm}^2}$$

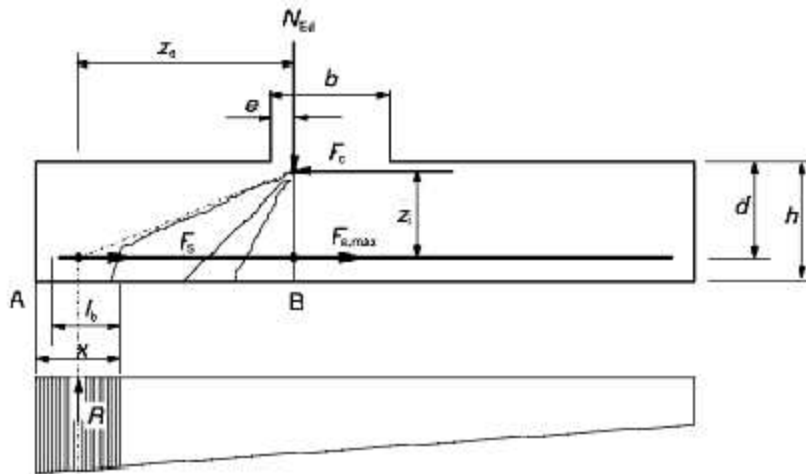

Kuva 9.13 Vinhalkeamien mukainen vetovimamalli

Anchoring

$$\eta_1 := 0.7 \quad \eta_2 := 1 \quad f_{bd} := 2.25 \eta_1 \cdot \eta_2 \cdot f_{ctd} = 2.13 \text{ MPa}$$

B1 direction(x)

$$e_x := 0.15 b_1 = 0.06 \text{ m} \quad z_{1x} := 0.9 d_x = 0.49 \text{ m}$$

$$ABx := \frac{B_1}{2} - \frac{b_1}{2} + e_x = 1.27 \times 10^3 \text{ mm} \quad p_{yEd} := 0.18 \text{ MPa}$$

$$\alpha_{1x} := 1 \quad \alpha_{2x} := 0.7 \quad \alpha_{3x} := 1.0 \quad \alpha_{5x} := 1 - 0.04 \frac{p_{yEd}}{\text{MPa}} = 0.99$$

Cracks h/2 distance from the pad side

$$x_{x1} := \frac{h}{2} = 0.3 \text{ m} \quad R_{x1} := x_{x1} \cdot B_2 \cdot p_{xEd} = 155.07 \text{ kN}$$

$$z_{ex1} := ABx - \frac{x_{x1}}{2} = 1.12 \text{ m} \quad F_{sx1} := \left( R_{x1} \cdot \frac{z_{ex1}}{z_{1x}} \right) = 355.08 \text{ kN}$$

$$\sigma_{ax1} := \frac{F_{sx1}}{A_{sx}} = 103.88 \text{ MPa}$$

$$l_{brqdx1} := \left( \frac{T_{sx}}{4} \right) \cdot \frac{\sigma_{ax1}}{f_{bd}} = 0.2 \text{ m}$$

$$l_{bdx1} := \alpha_{1x} \cdot \alpha_{2x} \cdot \alpha_{3x} \cdot \alpha_{5x} \cdot l_{brqdx1} = 0.14 \text{ m}$$

$$l_{bmaxprov1} := \frac{h}{2} - c_r = 0.25 \text{ m}$$

$$l_{bminx1} := \max(0.3 l_{brqdx1}, 10 T_{sx}, 100 \text{ mm}) = 0.16 \text{ m}$$

Crack at the side of the column

$$x_{x2} := ABx - e_x = 1.21 \text{ m} \quad R_{x2} := x_{x2} \cdot B_2 \cdot p_{xEd} = 625.44 \text{ kN}$$

$$z_{ex2} := \frac{x_{x2}}{2} = 0.61 \text{ m} \quad F_{sx2} := R_{x2} \cdot \frac{z_{ex2}}{z_{1x}} = 775.7 \text{ kN}$$

$$\sigma_{ax2} := \frac{F_{sx2}}{A_{sx}} = 226.94 \text{ MPa}$$

$$l_{brqdx2} := \left( \frac{T_{sx}}{4} \right) \cdot \frac{\sigma_{ax2}}{f_{bd}} = 0.43 \text{ m}$$

$$l_{bdx1} := \alpha_1 \cdot \alpha_2 \cdot \alpha_3 \cdot \alpha_5 \cdot l_{brqdx2} = 0.3 \text{ m}$$

$$l_{bmaxprovx1} := \frac{B_1}{2} - c_r - \frac{b_1}{2} = 1.16 \text{ m}$$

$$l_{bminx1} := \max(0.3 l_{brqdx1}, 10 T_{sx}, 100 \text{ mm}) = 0.16 \text{ m}$$

Crack check

Exposure class = XC2

Suurin tankokoko:			
Teräs-jännitys N/mm <sup>2</sup>	Suurin tankokoko		
	w <sub>k</sub> = 0.4	w <sub>k</sub> = 0.3	w <sub>k</sub> = 0.2
150	40	32	25
200	32	25	16
240	20	16	12
280	16	12	8
320	12	10	6
360	10	8	5
400	8	6	4
450	6	5	0

Suurin tankoväli:			
Teräs-jännitys N/mm <sup>2</sup>	Tankojaon enimmäisarvo		
	w <sub>k</sub> = 0.4	w <sub>k</sub> = 0.3	w <sub>k</sub> = 0.2
160	300	300	200
200	300	250	150
240	250	200	100
280	200	150	50
320	150	100	0
360	100	50	0

Moment y-axis

$$\sigma_{xsk} := \frac{M_{yik}}{A_{sxprov} \cdot z_{xik}} = 135.71 \frac{\text{N}}{\text{mm}^2}$$

Biggest rebar size T<sub>sx</sub> = 16mm and spacing 200mm

Moment x-axis

$$\sigma_{ysk} := \frac{M_{xik}}{A_{syprov} \cdot z_{yik}} = 70.22 \frac{\text{N}}{\text{mm}^2}$$

Biggest rebar size T<sub>sy</sub> = 32mm and spacing 300mm

Punching according to the Finnish B4 2.2.2.7

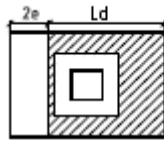

Tapaus 1

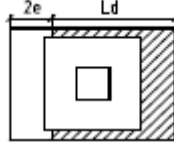

Tapaus 2

Punching, eccentricity y-axis

$$p_{EdLx} := \frac{N_{MyEd}}{B_2 \cdot L_{xd}} = 235.68 \frac{\text{kN}}{\text{m}^2} \quad \left[ 2 \cdot e_{xd} < \left( \frac{B_1}{2} \right) - \left( \frac{b_2}{2} \right) - d_x \right] = 1$$

$$V_{EdLx} := [B_2 \cdot L_{xd} - (b_1 + 2 \cdot d_x) \cdot (b_2 + 2 \cdot d_y)] \cdot p_{EdLx} = 540.42 \text{ kN}$$

$$v_{bn} := (b_1 + d_x) \cdot 2 + (b_2 + d_y) \cdot 2 = 3.46 \text{ m}$$

$$\rho_x := \frac{A_{sx}}{B_2 \cdot h} \quad \rho_y := \frac{A_{sy}}{B_1 \cdot h} \quad \rho := \min(\sqrt{\rho_x \cdot \rho_y}, 0.008) = 2.41 \times 10^{-3}$$

$$d := \frac{(d_x + d_y)}{2 \cdot m} = 0.53 \quad k := \max(1.6 - d, 1) = 1.07$$

$$\beta := \frac{0.4}{\left[ 1 + \frac{1.5 \cdot e_{xd}}{\sqrt{(b_1 + 2d_x) \cdot (b_2 + 2d_y)}} \right]} = 0.29$$

$$V_{Rdx} := k \cdot \beta \cdot (1 + 5\rho) \cdot v_{bn} \cdot \frac{(d_x + d_y)}{2} \cdot f_{ctd} = 8.73 \times 10^5 \text{ N}$$

Pad's EQU

$$N_{gk1} := 55 \text{ kN} \quad N_{gk3} := 37.8 \text{ kN} \quad N_{gk5} := 77.2 \text{ kN} \quad N_{qk4} := 5 \text{ kN}$$

$$M_{qk} := 21 \text{ kNm}$$

$$M_{gk} := 18 \text{ kNm} + 0.25620 \cdot 4 \text{ kNm} = 173.1 \text{ kNm}$$

$$N_{Ed} := 0.9(N_{gk1} + N_{gk3} + N_{gk5}) + 1.5N_{qk4} = 6.84 \times 10^5 \text{ N}$$

$$M_{Ed} := 1.1M_{gk} + 1.5M_{qk} = 5.14 \times 10^5 \text{ J}$$

$$e := \frac{M_{Ed}}{N_{Ed}} = 0.75 \text{ m}$$

$$\sigma_{Ed} := \frac{N_{Ed}}{B_2 \cdot (B_1 - 2 \cdot e)} = 263.89 \frac{\text{kN}}{\text{m}^2}$$

The roof's load combinations

The usual values are presented in the table

		Permanent	Wind	Snow	
		$\psi_0$	$\psi_0$	left	right
LC		$\psi_0$	$\psi_0$	$\psi_0$	$\psi_0$
WIND	12	1	1	0	0
SNOW	6	1	0	-1	-1
	13	1	0.6	1	1
SNOW LEFT	14	1	0.6	1	0.5

The partial safety factors

$\gamma_G := 1.1$ : Permanent loads

$\gamma_{Gmax} := 1.3$ : Permanent loads

$\gamma_{Gmin} := 0.9$ : Permanent loads

$\gamma_Q := 1.5$ : Imposed loads

$\psi_0 := 0.7$ : snow

$\psi_0 := 0.6$ : wind

The forces of the primary beam

The primary beam is designed for the LC13 forces

The primary beam

KY 13:  $G_{K1} G_{Kj}$  (dead load) +  $Q_{1K1} Q_{Kj}$  (snow) +  $Q_{1K1} 0.6 Q_{Ki}$  (wind) =  
 $1.15 * 1 * G_{Kj}$  (dead load) +  $1.5 * 1 * Q_{Kj}$  (snow) +  $1.5 * 1 * 0.6 Q_{Ki}$  (wind)

- $s := 6m$  Frame spacing
- $B := 24m$  Breath of the frame
- $H := 6.75m$  Building height
- $L := 6m$  Column height

The roof loads:

- $g_{k1} := 3 \frac{kN}{m^2}$  roof
- $g_{k2} := 1 \frac{kN}{m^2}$  Hanging loads
- $g_{k3} := 10 \frac{kN}{m}$  HI - prestressed beam

Snow load

$$q_{k1} := 2 \frac{\text{kN}}{\text{m}^2} \quad \text{snow}$$

Wind load

$$q_p = 0.61 \frac{\text{kN}}{\text{m}^2} \quad \text{wind}$$

$c_{scd} := 1.0$  Wind coefficient

$c_f := 1.3'$  Wind force factor

$$F_d := [12 \cdot [1.15 \cdot (3 + 1) + 1.5 \cdot 2 + 1.5 \cdot 0.6 \cdot 0.6] + 6 \cdot 10] \cdot \frac{\text{kN}}{\text{m}} = 157.68 \cdot \frac{\text{kN}}{\text{m}}$$

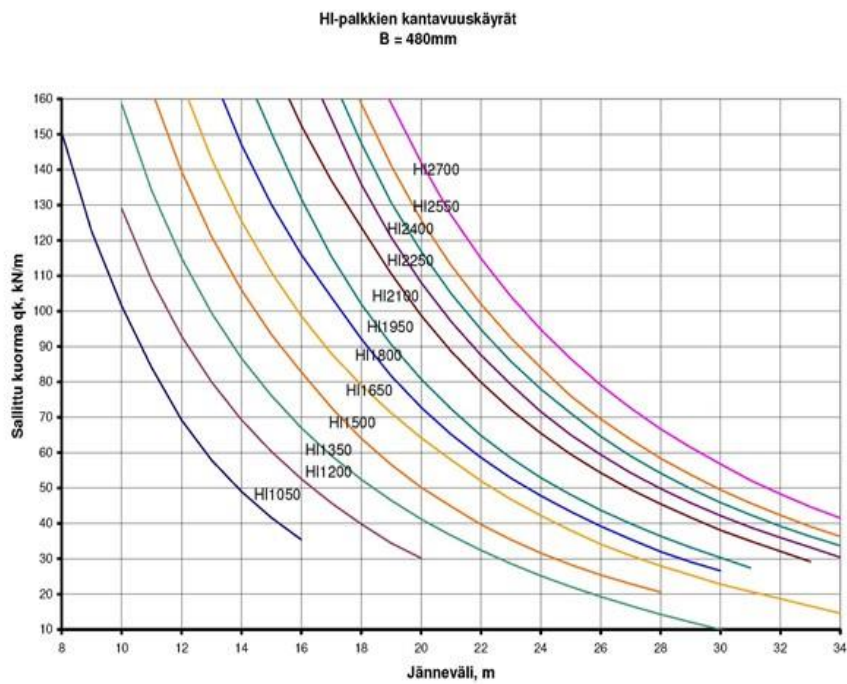

We choose HI- beam 480\*1350-1:16 and TT-slab's height 500mm

Start from column design:



The cantilever column is designed for the load combination LC3:

$$LC\ 3: \quad \gamma_G \cdot K_{f1} \cdot G_{kj} \text{ (dead load)} + \gamma_{Q,1} \cdot K_{f1} \cdot Q_{kj} \text{ (wind)} + \gamma_{Q,1} \cdot K_{f1} \cdot \sum \psi_{0j} \cdot Q_{ki} \text{ (snow)} = 1.15 \cdot 1 \cdot G_{kj} \text{ (dead load)} + 1.5 \cdot 1 \cdot Q_{kj} \text{ (wind)} + 1.5 \cdot 1 \cdot \sum 0.7 \cdot Q_{ki} \text{ (snow)}$$

$s := 12\text{m}$	Frame spacing
$B := 24\text{m}$	Breath of the frame
$H := 6.75\text{m}$	Building height
$L := 6\text{m}$	Column height

The roof loads:

$gk_1 := 3 \frac{\text{kN}}{\text{m}^2}$	roof
$gk_2 := 1 \frac{\text{kN}}{\text{m}^2}$	Hanging loads
$gk_3 := 10 \frac{\text{kN}}{\text{m}}$	HI - prestressed beam

Snow load

$qk_1 := 2 \frac{\text{kN}}{\text{m}^2}$	snow
--	------

Wind load

$q_p = 0.61 \frac{\text{kN}}{\text{m}^2}$	wind
---	------

$c_{scd} := 1.0$	Wind coefficient
------------------	------------------

$c_f := 1.3'$	Wind force factor
---------------	-------------------

$$\phi := \frac{1}{305}$$

$$Nd_3 := \left[ 1.15 \cdot (gk_1 + gk_2) + 1.5 \cdot 0.7 qk_1 \right] \cdot s \cdot \frac{B}{2} + 1.15 \cdot gk_3 \cdot \left( \frac{B}{2} \right) = 1102.8 \cdot \text{kN}$$

$$q_{wd} := 1.5 \cdot c_{scd} \cdot c_f \cdot q_p \cdot s = 14.95 \cdot \frac{\text{kN}}{\text{m}}$$

$$H := 6.75\text{m} \quad L = 6\text{m} \quad (gk_1 + gk_2 + qk_1) \cdot s \cdot \frac{B}{2} + gk_3 \cdot \frac{B}{2} = 984 \cdot \text{kN}$$

$$F_{wd} := q_{wd} \cdot (H - L) = 11.21 \text{kN}$$



Imperfections

$$\phi = 0$$

$$H_{eq} := 2 \cdot \phi \cdot Nd_3 = 7.23 \text{ kN}$$

$$Md_3 := \frac{5 \cdot q_{wd} \cdot L^2}{16} + \frac{F_{wd} \cdot L}{2} + \frac{H_{eq} \cdot L}{2} = 223.56 \text{ kNm}$$

The wind friction force is shared to the cantilever columns.

The column design with the nominal curvature method. (EC2, 5.5.8)

Column height

$$L := 6 \text{ m}$$

Section

$$b := 380 \text{ mm} \quad h := 380 \text{ mm}$$

Concrete C50/60 -1

$$f_{cd} := \left( \frac{0.8550}{1.35} \right) \cdot \frac{\text{N}}{\text{mm}^2} = 31.48 \frac{\text{N}}{\text{mm}^2}$$

Steel A500HW

$$f_{yd} := \left( \frac{500}{1.1} \right) \cdot \frac{\text{N}}{\text{mm}^2} = 454.55 \frac{\text{N}}{\text{mm}^2}$$

Concrete age

28 days

Concrete age with loading

$$E_s := 2 \cdot 10^5 \cdot \frac{\text{N}}{\text{mm}^2}$$

Exposure class XC1

2. First order forces

Loads:

$$N_{0Ed} := Nd_3 = 1102.8 \text{ kN}$$

$$M_d := Md_3 = 223.56 \text{ kNm}$$

Imperfection included

$$M_{0Eqp} := 150 \text{ kNm}$$

Imperfections

$$\alpha_h := \frac{2}{\sqrt{7}} = 0.76$$

$$\alpha_m := \sqrt{0.5 \left( 1 + \frac{1}{2} \right)} = 0.87$$

$$\phi_0 := \frac{1}{200} = 0.01$$

$$\phi_i := \phi_0 \cdot \alpha_h \cdot \alpha_m = 0$$

$$L := 6 \text{ m}$$

$$L_0 := 2.186 \text{ m} = 13.08 \text{ m}$$

24

$$e_i := \max \left( \phi_i \cdot \frac{L_0}{2}, \frac{h}{30}, 20 \text{ mm} \right)$$

$$e_i := 2 \text{ mm}$$

First order forces  $N_{0Ed}$   $M_{0Ed}$

$$N_{0Ed} = 1102.8 \text{ kN}$$

$$M_{01} := N_{0Ed} \cdot \frac{\phi_i}{2} \cdot L_0 = 23.6 \text{ kNm}$$

$$M_{02} := M_d = 223.56 \text{ kNm}$$

$$M_{0Ed} := M_{02} = 223.56 \text{ kNm}$$

### 3. Buckling length

Creep

$$RH := 50 \quad u := 2 \cdot (b + h) = 1.52 \text{ m} \quad A_c := b \cdot h = 0.14 \text{ m}^2$$

$$h_o := \frac{(2 \cdot A_c)}{u} = 190 \text{ mm}$$

$$\varphi_{rh}^{cal15} := 1 + \frac{\left[1 - \left(\frac{RH}{100}\right)\right]}{0.1 \cdot 190^3} = 1.87$$

$$f_{cm} := 58 \text{ MPa} \quad \beta_{f_{cm}} := \frac{16.8}{\sqrt{58}} = 2.21$$

$$t_o := 2\text{t} \quad \beta_{t_o} := \left[ \frac{1}{(0.1 + t_o^{0.2})} \right] = 0.49$$

$$\varphi_o := \varphi_{rh} \cdot \beta_{f_{cm}} \cdot \beta_{t_o} = 2.01$$

Limit value of the buckling length

$$\varphi_{ef} := \varphi_o \cdot \frac{M_{0Eqp}}{M_{0Ed}} = 1.35 \quad A_c := b \cdot h = 0.14 \text{ m}^2$$

$$A := \frac{1}{(1 + 0.2\varphi_{ef})} = 0.79$$

$$A_s := 4 \cdot \pi \cdot (16 \text{ mm})^2$$

$$\omega := \frac{(A_s \cdot f_{yd})}{A_c \cdot f_{cd}} = 0.32$$

$$B := \sqrt{1 + 2 \cdot \omega} = 1.28$$

$$r_m := \frac{M_{01}}{M_{02}} = 0.11 \quad C := 0.7 \quad \text{For unbraced column}$$

$$N_{Ed} := N_{0Ed} = 1102.8 \text{ kN} \quad n := \frac{N_{Ed}}{25 A_c \cdot f_{cd}} = 0.24$$

$$\lambda_{lim} := \frac{20 A \cdot B \cdot 0.7}{\sqrt{n}} = 28.68$$

Buckling length  $L := 6000\text{mm}$

$k_1 := 0.1$        $k_2 := 10^6$        $L_0 := 2.18L = 13080\text{mm}$

$h := 380\text{mm}$

$\lambda := \frac{L_0}{0.289h} = 119.1$       Which is bigger than  $\lambda_{lim}$

Second order forces must be included.

4. Second order forces

Exposure class XC2

Minimum cover due to bond anchoring

$c_{min.b} := 32\text{mm}$

Minimum cover due to environmental conditions

$c_{min.dur} := 20\text{mm} - 5\text{mm} = 15\text{mm}$

Addictive safety element

$c_{dur.\gamma} := 0$

Reduction for use of additions

$c_{dur.add} := 0$

$c_{min} := \max(c_{min.b}, c_{min.dur} + c_{dur.\gamma} - 0 - c_{dur.add}, 10\text{mm})$

$c_{min} := 32\text{mm}$

$c_{dev} := 10\text{mm}$

$c_{nom} := c_{min} + c_{dev} = 0.04\text{m}$

$d := h - c_{nom} = 0.34\text{m}$

$n_{bal} := 0.4$        $n_u := 1 + \omega = 1.32$

$K_r := \min\left[\frac{(n_u - n)}{(n_u - n_{bal})}, 1\right]$        $K_r := 1$

$f_{ck} := 50 \frac{\text{N}}{\text{mm}^2}$        $\beta := 0.35 + \frac{50}{200} - \frac{\lambda}{150} = -0.19$

$\varphi_{ef} := 1.12$

$K_{\varphi} := \max\left[1 + \beta \cdot \varphi_{ef}, 1\right]$        $K_{\varphi} := 1$

$f_{yd} := 4.54510^8 \text{Pa}$        $E_s := 2 \cdot 10^5 \cdot \frac{\text{N}}{\text{mm}^2}$        $d := 338\text{mm}$

Buckling length  $L := 6000\text{mm}$

$k_1 := 0.1$        $k_2 := 10^6$        $L_0 := 2.18L = 13080\text{mm}$

$h := 380\text{mm}$

$\lambda := \frac{L_0}{0.289h} = 119.1$       Which is bigger than  $\lambda_{lim}$

Second order forces must be included.

4. Second order forces

Exposure class XC2

Minimum cover due to bond anchoring

$c_{min.b} := 32\text{mm}$

Minimum cover due to environmental conditions

$c_{min.dur} := 20\text{mm} - 5\text{mm} = 15\text{mm}$

Addictive safety element

$c_{dur.\gamma} := 0$

Reduction for use of additions

$c_{dur.add} := 0$

$c_{min} := \max(c_{min.b}, c_{min.dur} + c_{dur.\gamma} - 0 - c_{dur.add}, 10\text{mm})$

$c_{min} := 32\text{mm}$

$c_{dev} := 10\text{mm}$

$c_{nom} := c_{min} + c_{dev} = 0.04\text{m}$

$d := h - c_{nom} = 0.34\text{m}$

$n_{bal} := 0.4$        $n_u := 1 + \omega = 1.32$

$K_R := \min\left[\frac{(n_u - n)}{(n_u - n_{bal})}, 1\right]$        $K_R := 1$

$f_{ck} := 50 \frac{\text{N}}{\text{mm}^2}$        $\beta := 0.35 + \frac{50}{200} - \frac{\lambda}{150} = -0.19$

$\varphi_{ef} := 1.12$

$K_{\varphi} := \max\left[1 + \beta \cdot \varphi_{ef}, 1\right]$        $K_{\varphi} := 1$

$f_{yd} := 4.54510^8 \text{Pa}$        $E_s := 2 \cdot 10^5 \cdot \frac{\text{N}}{\text{mm}^2}$        $d := 338\text{mm}$

$$e_2 := 0.1 \cdot \left[ \frac{(K_T \cdot K_\varphi \cdot f_{yd}) \cdot (L_0^2)}{0.45d \cdot E_s} \right] = 0.26\text{m}$$

$$M_2 := N_{0Ed} e_2 = 281.89\text{kNm}$$

5. Section design

$$M_{01} := N_{0Ed} \frac{\phi_i}{2} \cdot L_0 = 23.61\text{kNm}$$

$$M_{02} := M_d = 223.56\text{kNm}$$

$$M_{Ed} := M_{02} + M_2 = 505.46\text{kNm}$$

$$v := \frac{N_{0Ed}}{A_c \cdot f_{cd}} = 0.24$$

$$\mu := \frac{M_{Ed}}{b \cdot h^2 \cdot f_{cd}} = 0.29$$

$$\omega_{tot} := 0.1$$

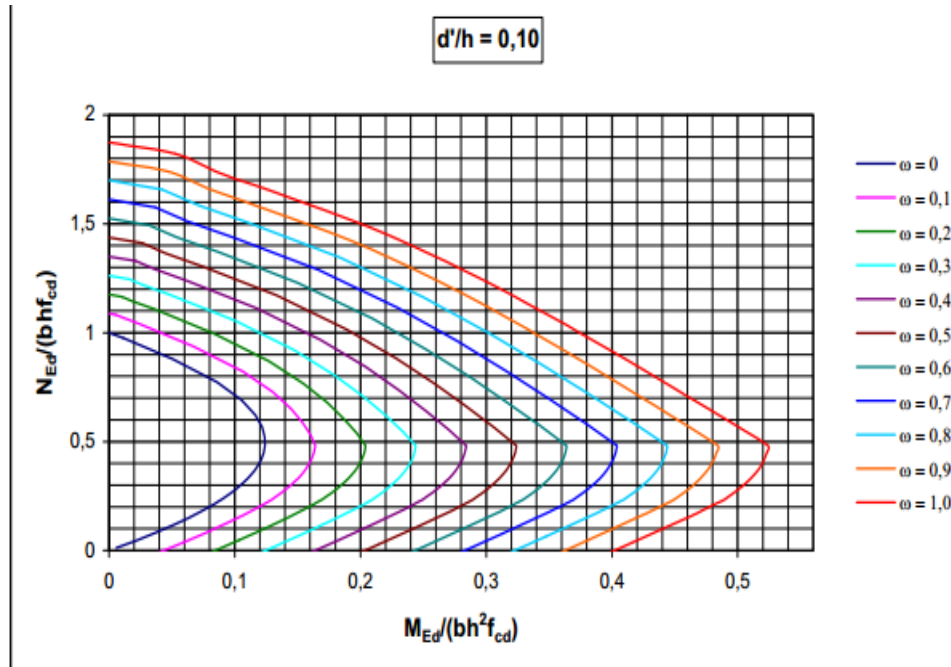

$$f_{cd} := 31.5 \frac{\text{N}}{\text{mm}^2} \qquad f_{yd} := 455 \frac{\text{N}}{\text{mm}^2}$$

$$A_s := \omega_{tot} \left( \frac{f_{cd}}{f_{yd}} \right) \cdot b \cdot h = 5998.15\text{mm}^2$$

One side needs 3000 mm<sup>2</sup>, let's choose T32 rears

$$4 \cdot \pi \cdot (16\text{mm})^2 = 3216.99\text{mm}^2$$

The maximum and minimum reinforcement areas of the column :

$$A_{s\min} := \max\left(0.1 \cdot \frac{N_{Ed}}{f_{yd}}, 0.002A_c\right) \quad A_{s\min} := 289\text{mm}^2$$

$$A_{s\max} := 0.06A_c = 8664\text{mm}^2$$

Stirrups

Stirrup's minimum diameter include 6mm or 0.25\* main reinforcement

Let us choose T8 stirrups

Stirrups spacing max 15\*

The end wall's corner column

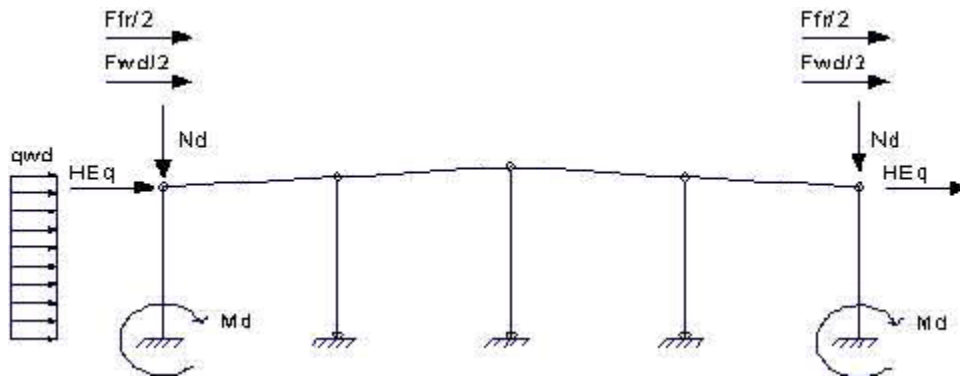

$$LC 3: G Kf1 Gkj \text{ (dead load)} + Q, 1 Kf1 Qkj \text{ (wind)} + Q, 1 Kf1 0jQki \text{ (snow)} = 1.15 * 1 * Gkj \text{ (dead load)} + 1.5 * 1 * Qkj \text{ (wind)} + 1.5 * 1 * 0.7 Qki \text{ (snow)}$$

- s := 12m Frame spacing
- B := 24m Breath of the frame
- H := 6.75m Building height
- L := 6m Column height

The roof loads:

- $gk_1 := 3 \frac{\text{kN}}{\text{m}^2}$  roof
- $gk_2 := 1 \frac{\text{kN}}{\text{m}^2}$  Hanging loads
- $gk_3 := 10 \frac{\text{kN}}{\text{m}}$  HI - prestressed beam

Snow load

$$qk_1 := 2 \frac{\text{kN}}{\text{m}^2} \quad \text{snow}$$

Wind load

$$qp = 0.61 \frac{\text{kN}}{\text{m}^2} \quad \text{wind}$$

$\psi_{sc} = 1.3$  Wind coefficient

$$N_{dw} := \left[ 1.15 \cdot (gk_1 + gk_2) + 1.5 \cdot 0.7 \cdot qk_1 \right] \cdot \frac{s}{2} \cdot \frac{B}{4} = 241.2 \cdot \text{kN}$$

$$q_{wd} := 1.5 \cdot \text{cscd} \cdot c_f \cdot \frac{B}{4} \cdot qp = 4.91 \cdot \frac{\text{kN}}{\text{m}}$$

$$M_{dw} := \frac{q_{wd} \cdot L^2}{8} = 22.1 \text{ kNm}$$

$$V_d := \left( \frac{5}{8} \right) \cdot q_{wd} \cdot L = 18.42 \cdot \text{kN}$$

The end wall's columns are assumed as having fixed bottom connections. The Columns are designed as cantilever columns supported at their top connections.

The fire design of the cantilever column

The section design in fire, R60

The forces and bending moments in fire  $N_{Edfi}$  and  $M_{0Edfi}$

The second order forces are included in the capacity curves.

$$N_{Edfi} := 580 \cdot \text{kN} \quad M_{0Edfi} := 34 \cdot \text{kNm}$$

$$b := 380 \text{ mm} \quad h := 380 \text{ mm} \quad f_{cd} = 31500000 \text{ Pa}$$

$$v_{fi} := \frac{N_{Edfi}}{b \cdot h \cdot f_{cd}} = 0.13$$

$$\mu_{fi} := \frac{M_{0Edfi}}{b \cdot h^2 \cdot f_{cd}} = 0.02$$

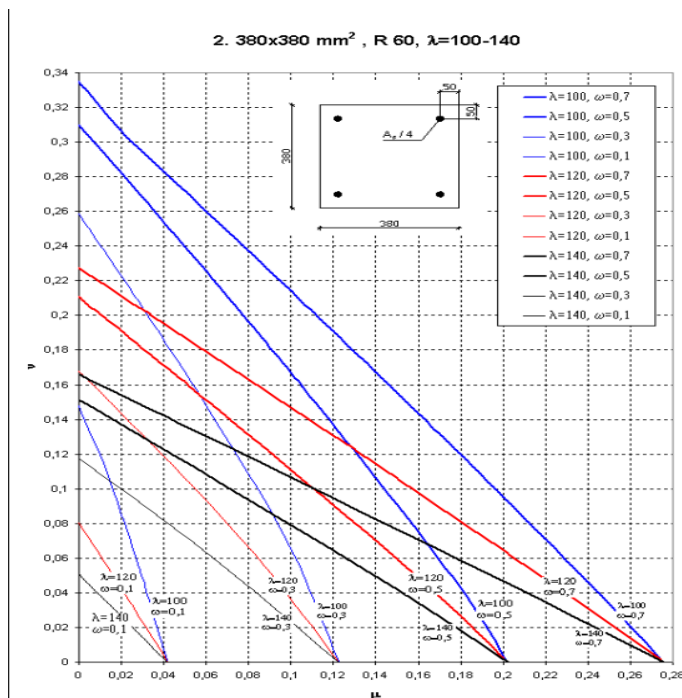

Because the column in our case Has same section height with column section 380\*380, so we can Consider they share the same diagram.

$$w_f := 0.2 \quad w_{tot} := 0.6$$

The mechanical reinforcement ratio In the normal temperature is  $\omega = 0.5$  Which is bigger than the value in fire, which means that the column 280\*380mm,  $a=50$ mm, has enough Capacity in the fire class R60

The column loads:

Transverse direction:  $N_{d1} := 1100\text{kN}$        $M_{d1} := M_{Ed} = 505.46\text{kNm}$

$N_{k1} := 745\text{kN}$        $M_{k1} := 350\text{kNm}$

Longitudinal direction:

$N_{d2} := 1100\text{kN}$        $M_{d2} := 17.8\text{kNm}$

$N_{k2} := 745\text{kN}$        $M_{k2} := 15\text{kNm}$

The pad size 3.2\*1.6\*0.6m<sup>3</sup>

floor design load:(storage load slab)

$N_{d3} := (1.51 \cdot 7.5 + 1.150 \cdot 1.525) \cdot 3.21.6\text{kN} = 79.68\text{kN}$

$N_{k3} := (1 \cdot 7.5 + 1 \cdot 0.1525) \cdot 3.21.6\text{kN} = 57.6\text{kN}$

Truck load

$Q_{dT} := 1.51 \cdot 1.44\text{kN} = 84\text{kN}$        $N_{d4} := 84\text{kN}$

$N_{k4} := 1 \cdot 1 \cdot 1.44\text{kN} = 56\text{kN}$

Extra truck load moment

$M_{d3} := 100\text{kNm}$

$M_{k3} := 57\text{kNm}$

Pad and fill load:

$N_{d5} := (1.150 \cdot 4.20 + 1.150 \cdot 6.25) \cdot 3.21.6\text{kN} = 135.42\text{kN}$

$N_{k5} := (1 \cdot 0.420 + 1 \cdot 0.625) \cdot 3.21.6\text{kN} = 117.76\text{kN}$

Pad transverse design load

$N_{dps} := N_{d1} + N_{d3} + N_{d4} + N_{d5} = 1399.1\text{kN}$

$M_{dps} := M_{d1} + M_{d3} = 605.46\text{kNm}$

$M_{kps} := M_{k1} + M_{k3} = 407\text{kNm}$

Pad longitudinal design load

$N_{dpp} := N_{d2} + N_{d3} + N_{d4} + N_{d5} = 1399.1\text{kN}$

$M_{dpp} := M_{d2} + M_{d3} = 117.8\text{kNm}$

$M_{kpp} := M_{k2} + M_{k3} = 72\text{kNm}$

Preliminary design:

Main column's pad

$B \cdot H \cdot L = 3200 \cdot 2400 \cdot 600 \text{ 17+17T20 C30/37}$



The column on ground pad

Loadings

$$N_{MyEd} := 1200 \text{ kN} \quad M_{yEd} := 560 \text{ kNm} \quad N_{MyEk} := 745 \text{ kN} \quad M_{yEk} := 407 \text{ kNm}$$

$$N_{MxEEd} := 1200 \text{ kN} \quad M_{xEd} := 117.8 \text{ kNm} \quad N_{MxEk} := 745 \text{ kN} \quad M_{xEk} := 72 \text{ kNm}$$

Concrete C30/37

$$\gamma_c := 1.5 \quad \alpha := 0.85 \quad \alpha_{ct} := 1.0 \quad f_{ck} := 30 \frac{\text{N}}{\text{mm}^2} \quad f_{ck2} := 30$$

$$f_{cd} := \frac{(\alpha \cdot f_{ck})}{\gamma_c} = 1700000 \text{ Pa} \quad f_{cm} := f_{ck} + 8 \cdot \frac{\text{N}}{\text{mm}^2} = 3800000 \text{ Pa}$$

$$f_{ctm} := 0.3 f_{ck2} \cdot \frac{2}{3} \cdot \frac{\text{N}}{\text{mm}^2} = 2896468 \text{ Pa} \quad f_{ctk005} := 0.7 f_{ctm} = 2027527 \text{ Pa}$$

$$f_{ctd} := \left( \alpha_{ct} \cdot \frac{f_{ctk005}}{\gamma_c} \right) = 1351685 \text{ Pa}$$

Steel

$$\gamma_s := 1.1 \quad f_{yk} := 500 \frac{\text{N}}{\text{mm}^2} \quad f_{yd} := \frac{f_{yk}}{\gamma_s} = 434782608 \text{ Pa}$$

Basic data

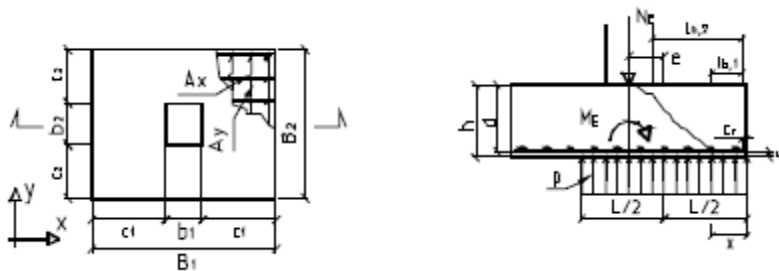

$$B_1 := 3200 \text{ mm} \quad B_2 := 2400 \text{ mm} \quad h := 600 \text{ mm} \quad c := 50 \text{ mm} \quad c_f := 50 \text{ mm}$$

$$b_1 := 380 \text{ mm} \quad b_2 := 380 \text{ mm} \quad T_{sx} := 16 \text{ mm} \quad T_{sy} := 16 \text{ mm}$$

$$d_x := h - c - \frac{T_{sx}}{2} = 0.54 \text{ m} \quad d_y := h - c - \left( T_{sx} + \frac{T_{sy}}{2} \right) = 0.53 \text{ m}$$

$$c_1 := \frac{(B_1 - b_1)}{2} = 1.41 \text{ m}$$

$$c_2 := \frac{(B_2 - b_2)}{2} = 1.01 \text{ m}$$

Data limits

$$B_1 \leq b_1 + 6 \cdot d_x = 1$$

$$B_1 \geq b_1 + 2 \cdot d_x = 1$$

$$B_2 \leq b_2 + 6 \cdot d_y = 1$$

$$B_2 \geq b_2 + 2 \cdot d_y = 1$$

Capacity

$$R_{dA} := 250 \frac{\text{kN}}{\text{m}}$$

Foundation dead load, reinforcement design

$$\rho_c := 25 \frac{\text{kN}}{\text{m}^3}$$

$$G_{fEd} := 1.15 B_1 \cdot B_2 \cdot h \cdot \rho_c = 132.48 \text{ kN}$$

Foundation dead load, EQU

$$G_{fEd2} := 0.9 B_1 \cdot B_2 \cdot h \cdot \rho_c = 103.68 \text{ kN}$$

$$G_{fEk} := 1.0 B_1 \cdot B_2 \cdot h \cdot \rho_c = 115.2 \text{ kN}$$

Foundation stress

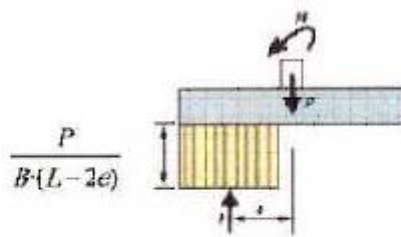

Kuva 2 Pilarianturan pohjapainejakauma STR ja GEO tarkasteluissa

Moment y-axis

$$e_{xd} := \frac{M_{yEd}}{(N_{MyEd} + G_{fEd})} = 0.42 \text{ m}$$

$$e_{xk} := \frac{M_{yEk}}{(N_{MyEk} + G_{fEk})} = 0.47 \text{ m}$$

$$L_{xd} := B_1 - 2 \cdot e_{xd} = 2.36 \text{ m}$$

$$L_{xk} := B_1 - 2 \cdot e_{xk} = 2.25 \text{ m}$$

$$p_{xEEd} := \frac{(N_{MyEd} + G_{fEd})}{B_2 \cdot L_{xd}} = 235.31 \frac{\text{kN}}{\text{m}^2}$$

$$p_{xEk} := \frac{(N_{MyEk} + G_{fEk})}{B_2 \cdot L_{xk}} = 159.03 \frac{\text{kN}}{\text{m}^2}$$

Moment x-axis

$$e_{yd} := \frac{M_{xEEd}}{(N_{MxEd} + G_{fEd})} = 0.09 \text{ m}$$

$$e_{yk} := \frac{M_{yEk}}{(N_{MyEk} + G_{fEk})} = 0.47 \text{ m}$$

$$L_{yd} := B_1 - 2 \cdot e_{yd} = 2.36 \text{ m}$$

$$L_{yk} := B_1 - 2 \cdot e_{yk} = 2.25 \text{ m}$$

$$p_{yEd} := \frac{(N_{MxEd} + G_{fEd})}{B_1 \cdot L_{yd}} = 176.48 \frac{\text{kN}}{\text{m}^2}$$

$$p_{yEk} := \frac{(N_{MxEk} + G_{fEk})}{B_1 \cdot L_{yk}} = 119.28 \frac{\text{kN}}{\text{m}^2}$$

Reinforcement

$$A_{sx} := 17 \pi \cdot \frac{T_{sx}^2}{4} = 3418.05 \text{ mm}^2$$

$$A_{sy} := 17 \pi \cdot \frac{T_{sy}^2}{4} = 3418.05 \text{ mm}^2$$

ULS Moment y-axis:

$$M_{yid} := 0.5 p_{xEEd} \cdot B_2 \cdot c_1^2 = 561.38 \text{ kNm}$$

$$\mu_{xid} := \frac{M_{yid}}{B_2 \cdot f_{cd} \cdot d_x^2} = 0.05$$

$$\beta_{xid} := 1 - \sqrt{1 - 2 \cdot \mu_{xid}} = 0.05$$

$$z_{xid} := d_x \cdot \left(1 - \frac{\beta_{xid}}{2}\right) = 0.53\text{m} \quad A_{svaadx} := \frac{M_{yid}}{z_{xid} \cdot f_{yd}} = 2440.8\text{mm}^2$$

$$A_{sminx} := \max\left[0.26 \left(\frac{f_{ctm}}{f_{yk}}\right) \cdot B_2 \cdot d_x, 0.0013 B_2 \cdot d_x, 0.2 A_{sy}\right] = 1959.2\text{mm}^2$$

$$A_{sxprov} := \max(A_{sy}, A_{svaadx}, A_{sminx}) = 3418.05\text{mm}^2$$

SLS moment y-axis:

$$M_{yik} := 0.5 p_{xEK} \cdot B_2 \cdot c_1^2 = 379.4\text{kNm}$$

$$\mu_{xik} := \frac{M_{yik}}{B_2 \cdot f_{cd} \cdot d_x^2} = 0.03 \quad \beta_{xik} := 1 - \sqrt{1 - 2 \cdot \mu_{xik}} = 0.03$$

$$z_{xik} := d_x \cdot \left(1 - \frac{\beta_{xik}}{2}\right) = 0.53\text{m} \quad F_{xikt} := \frac{M_{yik}}{z_{xik}} = 711.47\text{kN}$$

$$\sigma_{xsk} := \frac{M_{yik}}{A_{sxprov} \cdot z_{xik}} = 208.15 \frac{\text{N}}{\text{mm}^2}$$

ULS moment x-axis:

$$M_{xid} := 0.5 p_{yEd} \cdot B_1 \cdot c_2^2 = 288.0\text{kNm}$$

$$\mu_{yid} := \frac{M_{xid}}{B_1 \cdot f_{cd} \cdot d_y^2} = 0.02 \quad \beta_{yid} := 1 - \sqrt{1 - 2 \cdot \mu_{yid}} = 0.02$$

$$z_{yid} := d_y \cdot \left(1 - \frac{\beta_{yid}}{2}\right) = 0.52\text{m} \quad A_{svaady} := \frac{M_{xid}}{z_{yid} \cdot f_{yd}} = 1271.8\text{mm}^2$$

$$A_{sminy} := \max\left[0.26 \left(\frac{f_{ctm}}{f_{yk}}\right) \cdot B_1 \cdot d_y, 0.0013 B_1 \cdot d_y, 0.2 A_{sx}\right] = 2535.17\text{mm}^2$$

$$A_{syprov} := \max(A_{sy}, A_{svaady}, A_{sminy}) = 3418.05\text{mm}^2$$

SLS moment y-axis:

$$M_{xik} := 0.5 p_{yEK} \cdot B_1 \cdot c_2^2 = 194.68\text{kNm}$$

$$\mu_{yik} := \frac{M_{xik}}{B_2 \cdot f_{cd} \cdot d_y^2} = 0.02 \quad \beta_{yik} := 1 - \sqrt{1 - 2 \cdot \mu_{yik}} = 0.02$$

$$z_{yik} := d_y \cdot \left(1 - \frac{\beta_{yik}}{2}\right) = 0.52\text{m} \quad F_{yikt} := \frac{M_{xik}}{z_{yik}} = 373.36\text{kN}$$

$$\sigma_{ysk} := \frac{M_{xik}}{A_{syprov} \cdot z_{yik}} = 109.23 \frac{\text{N}}{\text{mm}^2}$$

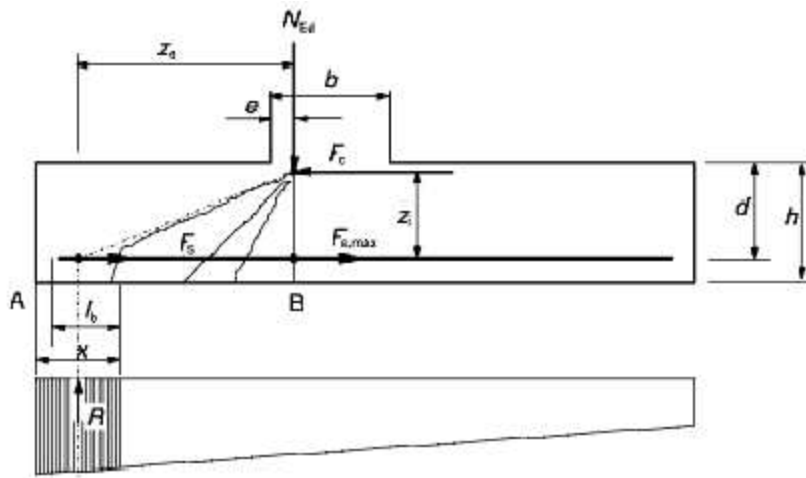

Kuva 9.13 Vinohalkeamien mukainen vetovoimamalli

Anchoring

$$\eta_1 := 0.7 \quad \eta_2 := 1 \quad f_{bd} := 2.25 \eta_1 \cdot \eta_2 \cdot f_{ctd} = 2.13 \text{ MPa}$$

B1 direction(x)

$$e_x := 0.15 b_1 = 0.06 \text{ m} \quad z_{1x} := 0.9 d_x = 0.49 \text{ m}$$

$$ABx := \frac{B_1}{2} - \frac{b_1}{2} + e_x = 146.7 \text{ mm} \quad P_{yEd} := 0.18 \text{ MPa}$$

$$\alpha_{1x} := 1 \quad \alpha_{2x} := 0.7 \quad \alpha_{3x} := 1.0 \quad \alpha_{5x} := 1 - 0.04 \frac{P_{yEd}}{\text{MPa}} = 0.99$$

Cracks h/2 distance from the pad side

$$x_{x1} := \frac{h}{2} = 0.3 \text{ m} \quad R_{x1} := x_{x1} \cdot B_2 \cdot P_{xEd} = 169.42 \text{ kN}$$

$$z_{ex1} := ABx - \frac{x_{x1}}{2} = 1.32 \text{ m} \quad F_{sx1} := \left( R_{x1} \cdot \frac{z_{ex1}}{z_{1x}} \right) = 457.42 \text{ kN}$$

$$\sigma_{ax1} := \frac{F_{sx1}}{A_{sx}} = 133.82 \text{ MPa}$$

$$l_{brqdx1} := \left( \frac{T_{sx}}{4} \right) \cdot \frac{\sigma_{ax1}}{f_{bd}} = 0.25 \text{ m}$$

$$l_{bdx1} := \alpha_{1x} \alpha_{2x} \alpha_{3x} \alpha_{5x} l_{brqdx1} = 0.17 \text{ m}$$

Suurin tankokoko:			
Teräs-jännitys N/mm <sup>2</sup>	Suurin tankokoko		
	w <sub>k</sub> = 0.4	w <sub>k</sub> = 0.3	w <sub>k</sub> = 0.2
160	40	32	25
200	32	25	16
240	20	16	12
280	16	12	8
320	12	10	6
360	10	8	5
400	8	6	4
450	6	5	0

Suurin tankoväli:			
Teräs-jännitys N/mm <sup>2</sup>	Tankojaon enimmäisarvo		
	w <sub>k</sub> = 0.4	w <sub>k</sub> = 0.3	w <sub>k</sub> = 0.2
160	300	300	200
200	300	250	150
240	250	200	100
280	200	150	50
320	150	100	0
360	100	50	0

Moment y-axis

$$\sigma_{xsk} := \frac{M_{yik}}{A_{sxprov} \cdot z_{xik}} = 208.15 \frac{N}{mm^2}$$

Biggest rebar size T<sub>sx</sub> = 16mm and spacing 200mm

Moment x-axis

$$\sigma_{ysk} := \frac{M_{xik}}{A_{syprov} \cdot z_{yik}} = 109.23 \frac{N}{mm^2}$$

Biggest rebar size T<sub>sy</sub> = 32mm and spacing 300mm

Punching according to the Finnish B4 2.2.2.7

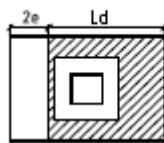

Tapaus 1

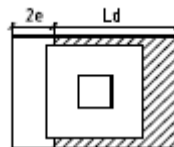

Tapaus 2

Punching, eccentricity y-axis

$$p_{EdLx} := \frac{N_{MyEd}}{B_2 \cdot L_{xd}} = 211.91 \frac{kN}{m^2} \quad \left[ 2 \cdot e_{xd} < \left( \frac{B_1}{2} \right) - \left( \frac{b_2}{2} \right) - d_x \right] = 1$$

$$V_{EdLx} := [B_2 \cdot L_{xd} - (b_1 + 2 \cdot d_x) \cdot (b_2 + 2 \cdot d_y)] \cdot p_{EdLx} = 755.74 kN$$

$$v_{bn} := (b_1 + d_x) \cdot 2 + (b_2 + d_y) \cdot 2 = 3.66 m$$

$$\rho_x := \frac{A_{sx}}{B_2 \cdot h} \quad \rho_y := \frac{A_{sy}}{B_1 \cdot h} \quad \rho := \min(\sqrt{\rho_x \cdot \rho_y}, 0.008) = 0$$

$$d := \frac{(d_x + d_y)}{2 \cdot m} = 0.53 \quad k := \max(1.6 - d, 1) = 1.07$$

$$\beta := \frac{0.4}{\left[ 1 + \frac{1.5 \cdot e_{xd}}{\sqrt{(b_1 + 2d_x) \cdot (b_2 + 2 \cdot d_y)}} \right]} = 0.28$$

$$V_{Rdx} := k \cdot \beta \cdot (1 + 5\rho) \cdot v_{bn} \cdot \frac{(d_x + d_y)}{2} \cdot f_{ctd} = 864491.0 N$$

The roof's load combinations

The usual values are presented in the table

		Permanent	Wind	Snow	
		$\psi_0$	$\psi_0$	left	right
	LC	$\psi_0$	$\psi_0$	$\psi_0$	$\psi_0$
WIND	12	1	1	0	0
SNOW	6	1	0	-1	-1
	13	1	0.6	1	1
SNOW LEFT	14	1	0.6	1	0.5

The partial safety factors

$\gamma_G := 1.1$ : Permanent loads

$\gamma_{Gmax} := 1.3$ : Permanent loads

$\gamma_{Gmin} := 0.9$ : Permanent loads

$\gamma_Q := 1.5$ : Imposed loads

$\psi_0 := 0.7$ : snow

$\psi_0 := 0.6$ : wind

The primary beam

KY 13:  $G_{K1} G_{Kj}$  (dead load) +  $Q_{K1} Q_{Kj}$  (snow) +  $Q_{K1} Q_{Ki}$  (wind) =  
 $1.15 * 1 * G_{Kj}$  (dead load) +  $1.5 * 1 * Q_{Kj}$  (snow) +  $1.5 * 1 * 0.6 Q_{Ki}$  (wind)

$s := 6m$  Frame spacing

$B := 24m$  Breath of the frame

$H := 6.75m$  Building height

$L := 6m$  Column height

The roof loads:

$g_{k1} := 3 \frac{kN}{m^2}$  roof

$g_{k2} := 1 \frac{kN}{m^2}$  hanging loads

$g_{k3} := 10 \frac{kN}{m}$  HI - prestressed beam

Snow load

$q_{k1} := 2 \frac{kN}{m^2}$  snow

Wind load

$q_p = 0.61 \frac{kN}{m^2}$  wind

$F_{pd} = 1.3 \cdot [1.15 \cdot (3 + 1) + 1.5 \cdot 2 + 1.5 \cdot 0.6 \cdot 0.6] + 6 \cdot 10] \cdot \frac{kN}{m} = 157.68 \frac{kN}{m}$  wind force factor

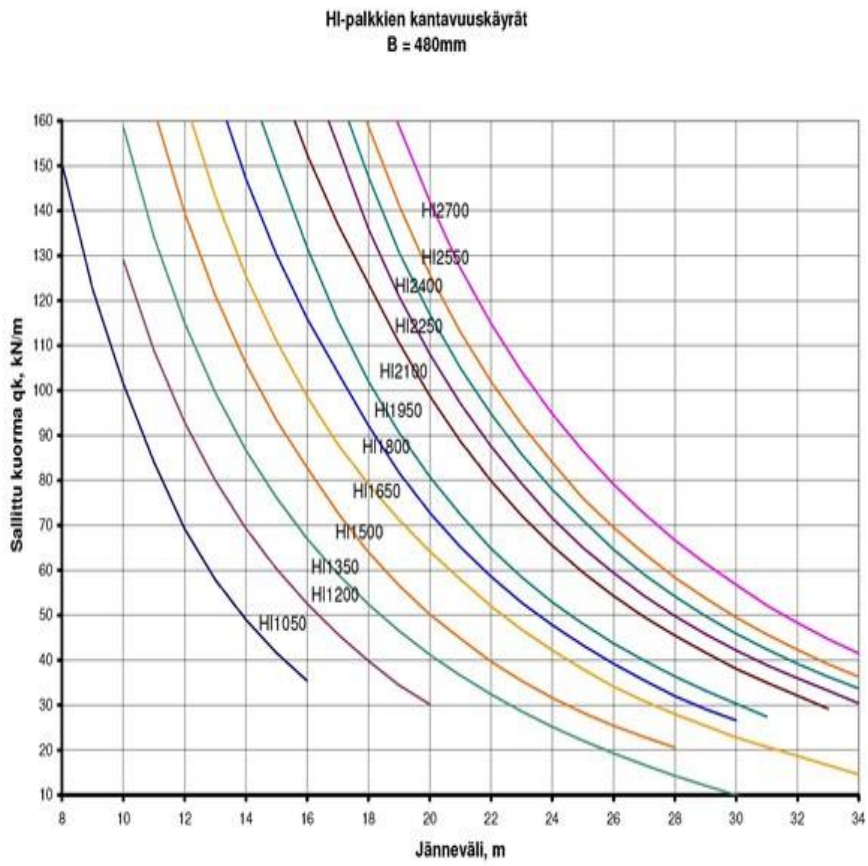

We choose HI- beam 480\*1650-1:16 and TT-slab's height 400mm